



SPECIFICATIONS

CUSTOMER : _____

MODEL NO. : **GFTO090AA1024600V**

VERSION : **A**

DATE : **2017.12.20**

CERTIFICATION : **ROHS**

CUSTOMER SIGN : _____

QA Approved By	Approved By	Prepared By	Prepared By
			

晶發科技股份有限公司
GI FAR TECHNOLOGY CO., LTD.

新北市樹林區東豐街 81 號

No. 81, Dongfeng St, Shulin District, 23874, New Taipei City, Taiwan, R.O.C.

TEL: +886-2-8684-1188 FAX: +886-2-8684-8532



Revision Record

Data(y/m/d)	Ver.	Description	Note	page
2017.12.20	A	New		



CONTENTS

NO.	Table of Content	Page
1	OVERVIEW	4
2	ABSOLUTE MAXIMUM RATINGS	5
3	ELECTRICAL CHARACTERISTICS	6
4	INTERFACE CONNECTION	10
5	INPUT SIGNAL(DE ONLY MODE)	12
6	MECHANICAL DIMENSION	14
7	OPTICAL CHARACTERISTICS	16
8	RELIABILITY TEST	18
9	WARRANTY	19



1. OVERVIEW

This is 9" color TFT-LCD (Thin Film Transistor Liquid Crystal Display) module composed of LCD panel, driver ICs ,control circuit and LED backlight. By applying 1024×600 images are displayed on the 9" diagonal screen. Display 16.2M colors by R.G.B signal input.

General specification are summarized in the following table:

ITEM	SPECIFICATION			
Display Area (mm)	196.608(W) x 114.15(H)			
Number of Pixels	1024(H) × 3 (RGB) × 600(V)			
Pixel Pitch (mm)	0.192(W) x 0.19025(H)			
Color Pixel Arrangement	RGB vertical stripe			
Display Mode	Normally white			
Number of Colors	16.2M			
Viewing Direction	6 o'clock (Max. contrast ratio, Gray level inversion)			
Brightness (cd/m ²)	500nit(typ)			
Response Time (ms)	25ms(typ.)			
Contrast Ratio	800:1			
Viewing Angle (CR ≥ 10)	140degree (Horizontal.)			
	120degree (Vertical)			
Power Consumption (W)	PLCD= 0.447 W (typ)/ 0.636 W (max); PLED=2.496 (typ)/ 2.769 (max) Total=2.943(typ)/ 3.405(max)			
Interface connection	LVDS			
Module Size (mm)		Min.	Typ.	Max.
	Horizontal (H)	210.8	211.1	211.4
	Vertical (V)	126.2	126.5	126.8
	Depth (D) w/o FPC	5.4	5.7	6.0
Module Weight (g)	240(typ)			
Backlight Unit	LED			
Surface Treatment	Anti-Glare, 3H			



2. ABSOLUTE MAXIMUM RATINGS

The following are maximum values which, if exceeded, may cause faulty operation or damage to the unit.

Item	Symbol	Min.	Max.	Unit	Note
Digital Supply Voltage	DVDD DVDD_LVDS	-0.3	3.96	V	
Analog Supply Voltage	AVDD	-0.5	14.85	V	
Gate On Voltage	VGH	-0.3	40	V	
Gate Off Voltage	VGL	-20	0.3	V	
Gate On-Gate Off Voltage	VGH-VGL	-0.3	40	V	
Signal Input Voltage	NIN0 ~ NIN3 PIN0 ~ PIN3 NINC, PINC	-0.5	5	V	
Forward Current (per LED)	If	-	30	mA	
Reverse Voltage (per LED)	VR	-	5	V	
Pulse forward current (per LED)	I _{fp}	-	80	mA	1,2
Operation Temperature (LCD panel surface overall)	T _{op1}	-20	80	°C	3,4
Operation Temperature (Ambient temperature)	T _{op}	-20	70	°C	3,4
Storage Temperature	T _{stg}	-30	80	°C	3,4

Note1 : I_{fp} Conditions : Duty ≤ 1/10 @ Pulse Width ≤ 10msec

Note2 : Each one of LED operation must be follow diagram of Ambient Temperature and Allowable Forward Current.

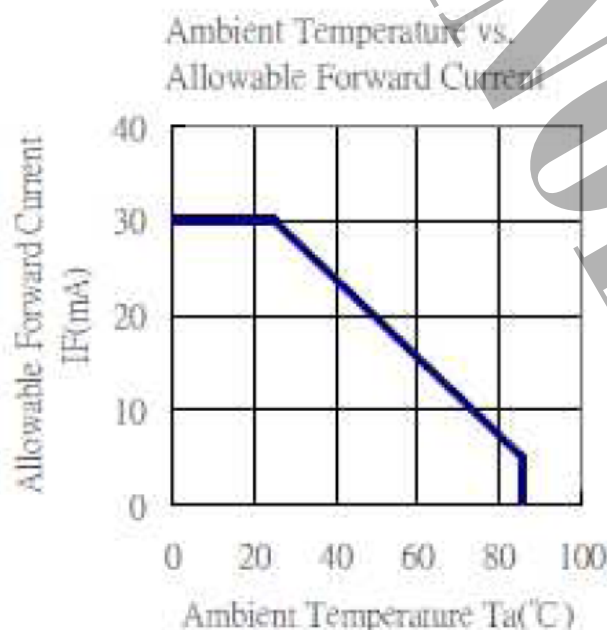

Note3 : If users use the product out off the environmental operation range (temperature and humidity) , it will have visual quality concerns.

Note4 : If the product were used out of the operation and storage range, it will have quality issue.



3. ELECTRICAL CHARACTERISTICS

3.1 TFT LCD

Ta=25°C

ITEM	SYMBOL	MIN	TYP	MAX	UNIT	NOTE
Digital Power Supply Voltage For LCD	DVDD DVDD_LVDS	3	3.3	3.6	V	
Logic Input Voltage (LVDS:IN+,IN-)	VCM	$\frac{ VID }{2}$	-	$2.4 - \frac{ VID }{2}$	V	Note1
	VID	200	-	600	mV	Note1
	VTH	-	-	100	mV	VCM=1.2V Note1
	VTL	-100	-	-	mV	
Analog Power Supply Voltage	AVDD	9.4	9.6	9.8	V	
Gate On Power Supply Voltage	VGH	17	18	19	V	
Gate Off Power Supply Voltage	VGL	-6.6	-6	-5.4	V	
Common Power Supply Voltage	VCOM	(3.1)	(3.3)	(3.5)	V	Note2

Note1 : LVDS signal

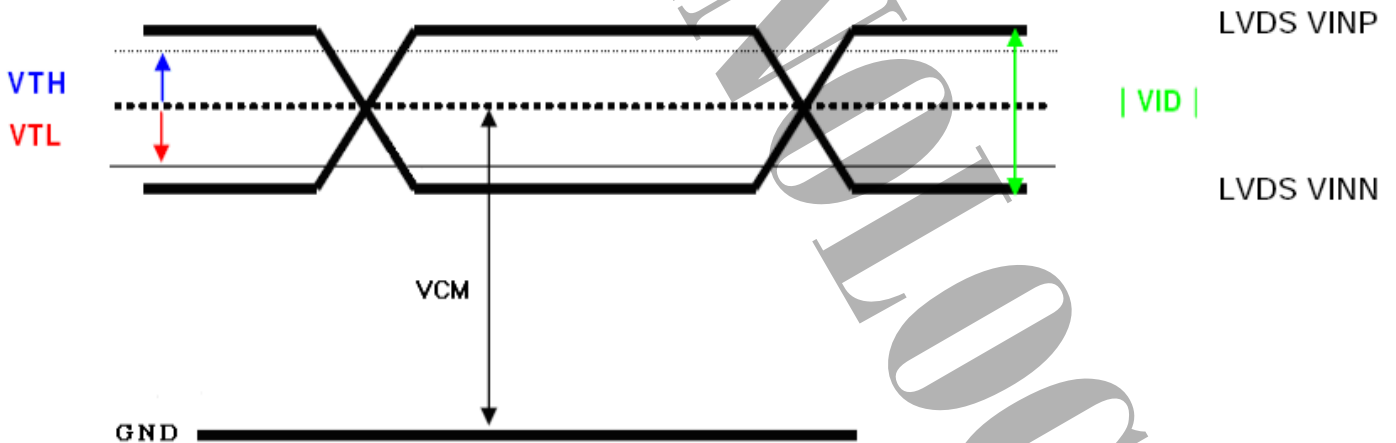

Note2 : Please adjust VCOM to make the flicker level be minimum.



3.2 TFT-LCD Current Consumption

Item	Symbol	Condition	Min.	Typ.	Max.	Unit	Note
Gate on power current	IVGH	VGH = 18V	-	0.5	1	mA	Note1
Gate off power current	IVGL	VGL = -6V	-	0.5	1	mA	Note1
Digital power current	IVDD	VDD = 3.3V	-	30	40	mA	Note1
Analog power current	IAVDD	AVDD = 9.6V	-	35	50	mA	Note1
Total Power Consumption	PC		-	447	636	mW	Note1

Note1 : Typical: Under 256 gray pattern
Maximum: Under black pattern



256 gray pattern



Black Pattern



3.3 Power · Signal sequence

Power On : DVDD→AVDD/VGL→VGH→Video & Logic Signal→Backlight

Power Off : Backlight→Video & Logic Signal→VGH→AVDD/VGL→DVDD

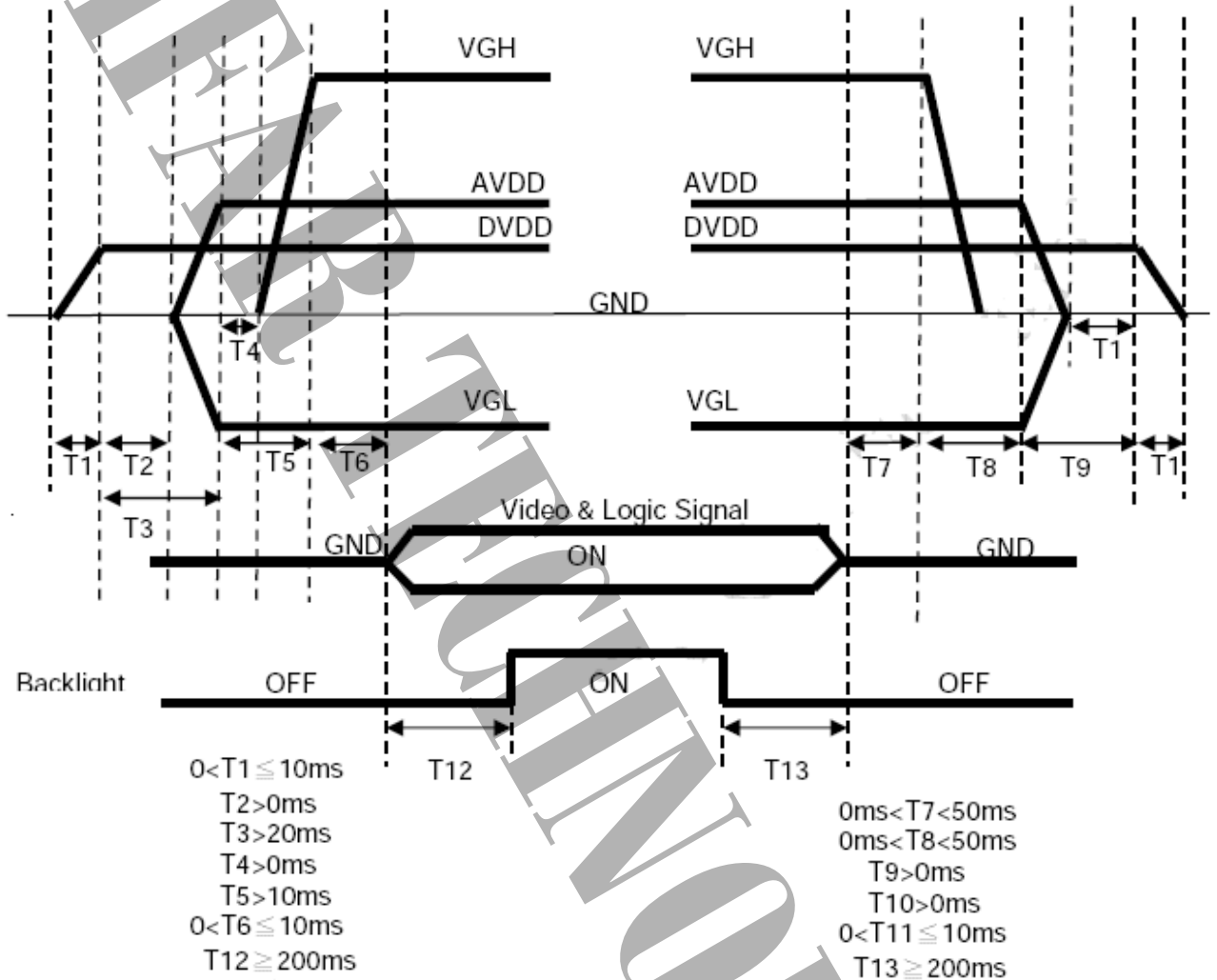



3.4 Backlight

Ta=25°C

ITEM	SYMBOL	CONDITIONS	MIN	TYP	MAX	UNIT	NOTE
LED current	IL	Ta=25°C (20mA/serise)	--	260	--	mA	
LED voltage	VL	Ta=25°C (20mA/serise)	8.55	9.6	10.65	V	
Power consumption	WL	Ta=25°C (20mA/serise)	--	2.496	--	W	
LED Lifetime	-	Ta=25°C IF=20mA	30000	--	--	Hr	

Remarks :

*1) LED Circuit Diagram

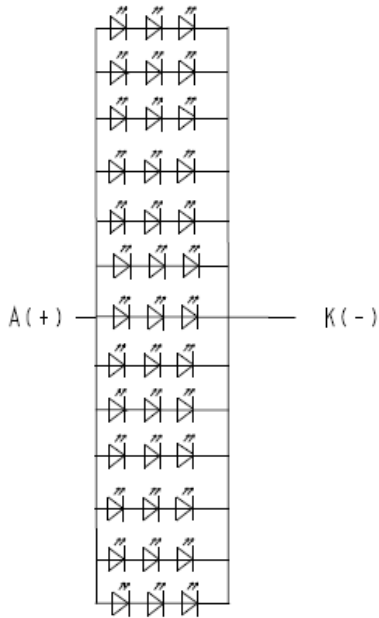

*2) A : Anode(+) , K : Cathode(-)

*3) Suggestion: Using the constant current control to avoid the leakage light and brightness quality issue.

*4) Definition of Led lifetime : Luminance < Initial luminance 50%.



4. INTERFACE CONNECTION

4.1 CN1 (Input Signal)

PIN NO	SYMBOL	DESCRIPTION
1	VCOM	Common voltage
2	DVDD	Digital power
3	DVDD	Digital power
4	NC	Not connect
5	RESET	Global reset pin. Active low to enter reset state. Suggest to connecting with an RC reset circuit for stability. Normally pull high. (R=10KΩ · C=1μF)
6	U/D	Vertical inversion
7	L/R	Horizontal inversion
8	STBYB	Standby mode, normally pull high STBYB="1", normal operation STBYB="0", timing control, source driver will turn off, all output are high-Z
9	GND	Ground
10	NINC	Negative LVDS differential clock inputs
11	PINC	Positive LVDS differential clock inputs
12	GND	Ground
13	NIND0	Negative LVDS differential data inputs
14	PIND0	Positive LVDS differential data inputs
15	GND	Ground
16	NIND1	Negative LVDS differential data inputs
17	PIND1	Positive LVDS differential data inputs
18	GND	Ground
19	NIND2	Negative LVDS differential data inputs
20	PIND2	Positive LVDS differential data inputs
21	GND	Ground
22	NIND3	Negative LVDS differential data inputs
23	PIND3	Positive LVDS differential data inputs
24	GND	Ground
25	SELB	6-bit/8-bit input select SELB = L , 8-bit ; SELB = H , 6-bit
26	GND	Ground
27	AVDD	Power for Analog Circuit
28	GND	Ground
29	VGH	Positive power for TFT
30	NC	Not connect
31	NC	Not connect
32	VGL	Negative power for TFT
33	GND	Ground
34	NC	Not connect
35	NC	Not connect
36	NC	Not connect
37	NC	Not connect
38	NC	Not connect
39	NC	Not connect
40	NC	Not connect

Remarks :

- 1) Mating connector : FH12A-40S-0.5SH
- 2) UD and LR control function



4.2 CN2 (LED backlight)

UD	LR	FUNCTION
0	1	Normal display
0	0	Inverse Left and Right
1	1	Inverse Up and Down
1	0	Inverse Left and Right Inverse Up and Down

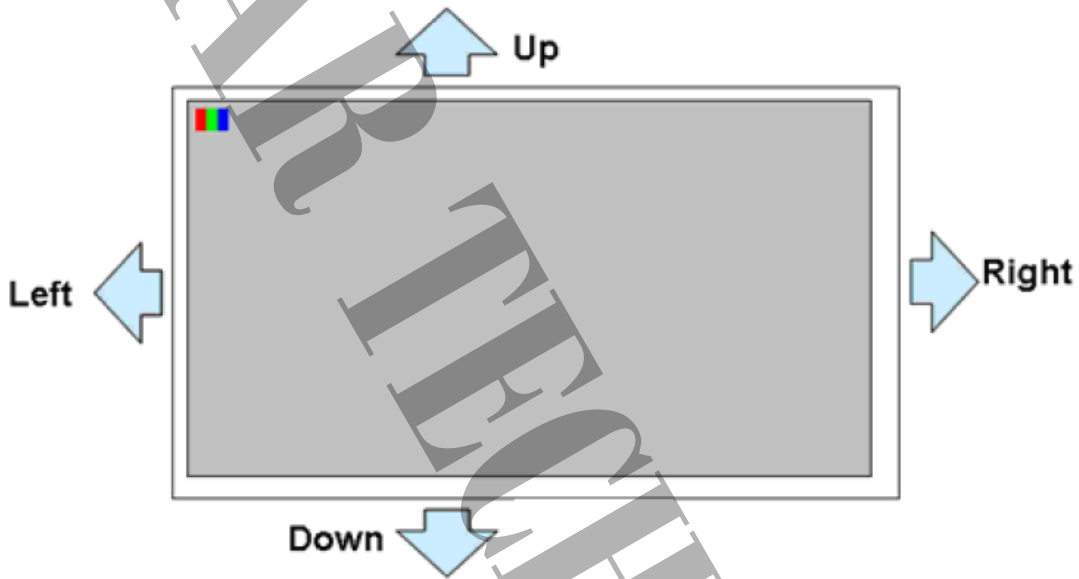

4.2 CN2 (LED backlight)

PIN NO	SYMBOL	FUNCTION
1	A	Anode
2	K	Cathode

Note :

Input connector : BHSR-02VS-1(JST)

Outlet connector: SM02B-BHSS-1(JST)



5. INPUT SIGNAL(DE ONLY MODE)

5.1 Timing Specification

ITEM		SYMBOL	MIN	TYP	MAX	UNIT	
LVDS input signal sequence	CLK Frequency	tclk	45	51.2	57	MHz	
LCD input signal sequence (Input LVDS Transmitter)	Horizontal	Horizontal total Time	t _H	1324	1344	1364	tCLK
		Horizontal effective Time	t _{HA}	1024			tCLK
		Horizontal Blank Time	t _{HB}	300	320	340	tCLK
	Vertical	Vertical total Time	t _V	625	635	645	t _H
		Vertical effective Time	t _{VA}	600			t _H
		Vertical Blank Time	t _{VB}	25	35	45	t _H

5.2 Timing sequence(Timing chart)

5.2.1 Horizontal Timing Sequence

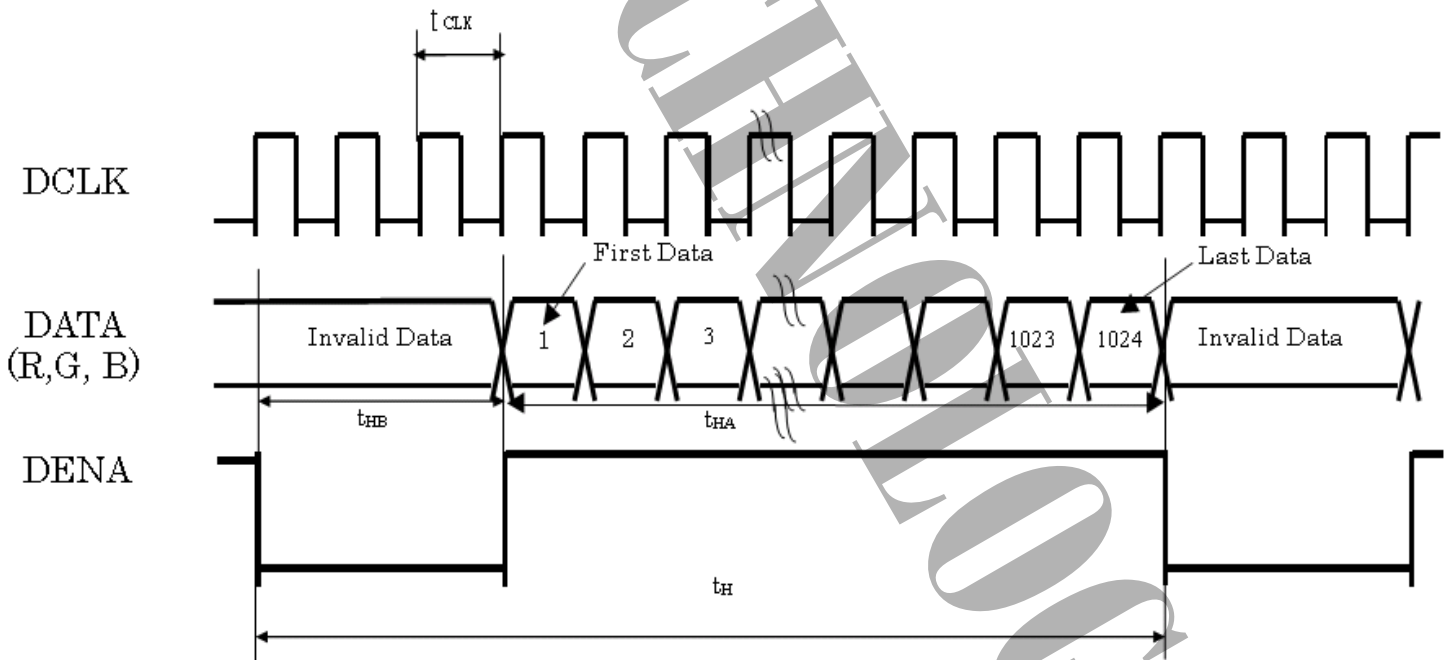



5.2.2 Vertical Timing Sequence

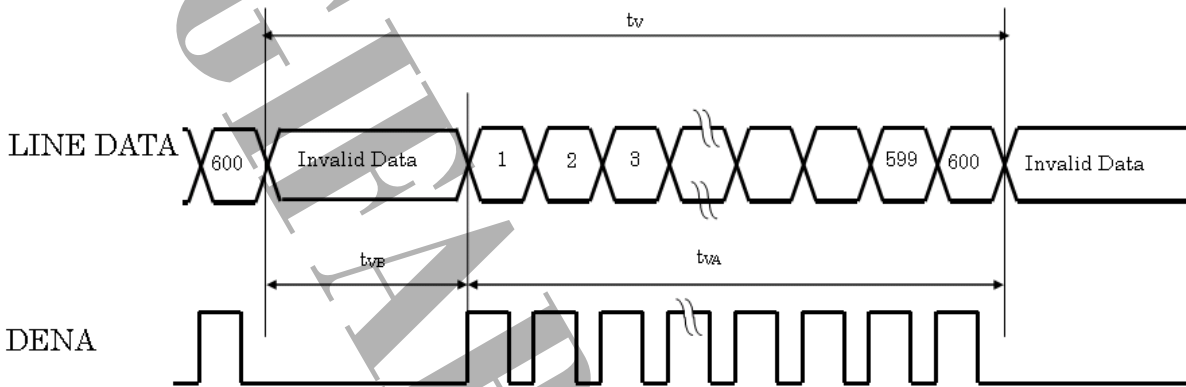

5.2.3 LVDS Input Data mapping

6 Bit LVDS input

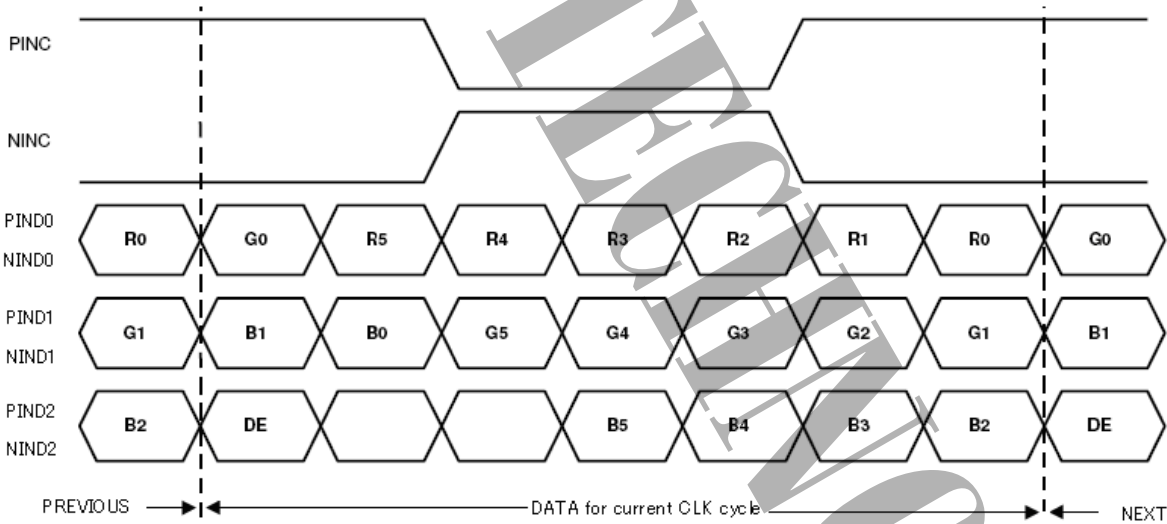

8 Bit LVDS input

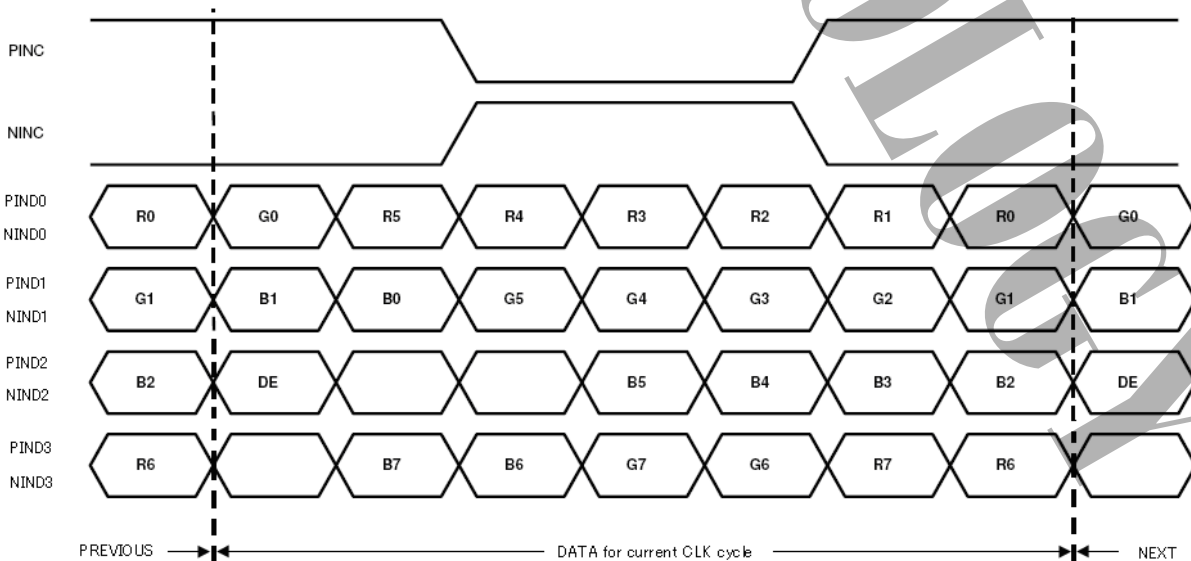



6. MECHANICAL DIMENSION

6.1 Front Side

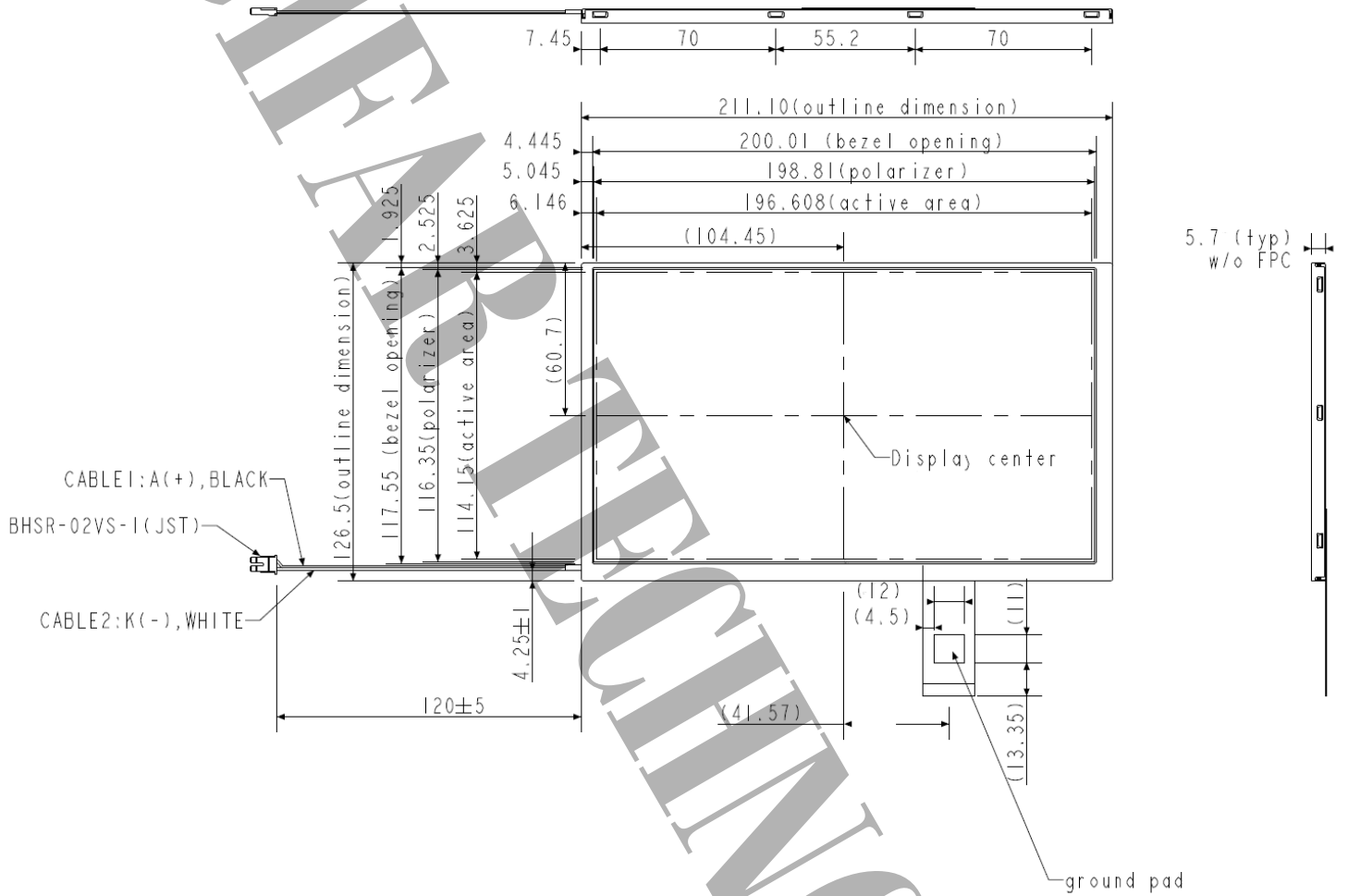

Remark: General tolerance ±0.3mm



6.2 Rear Side

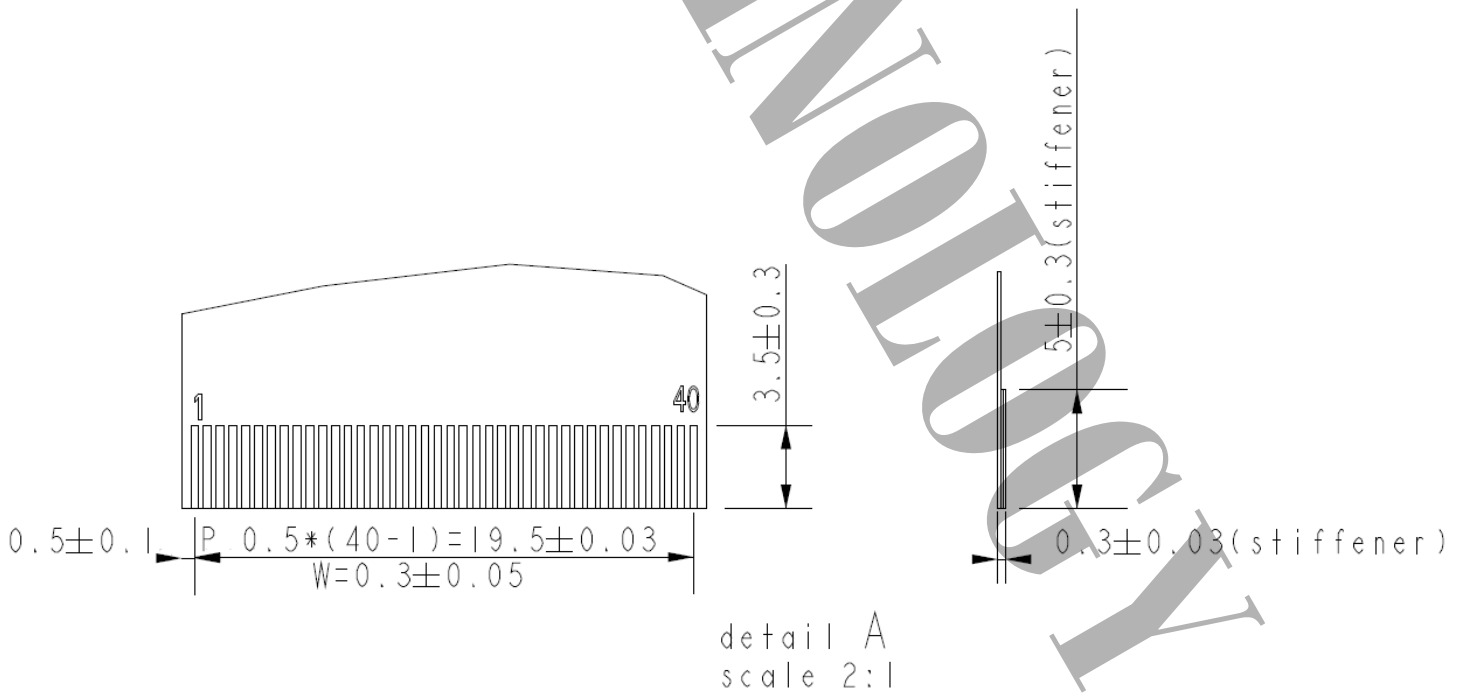
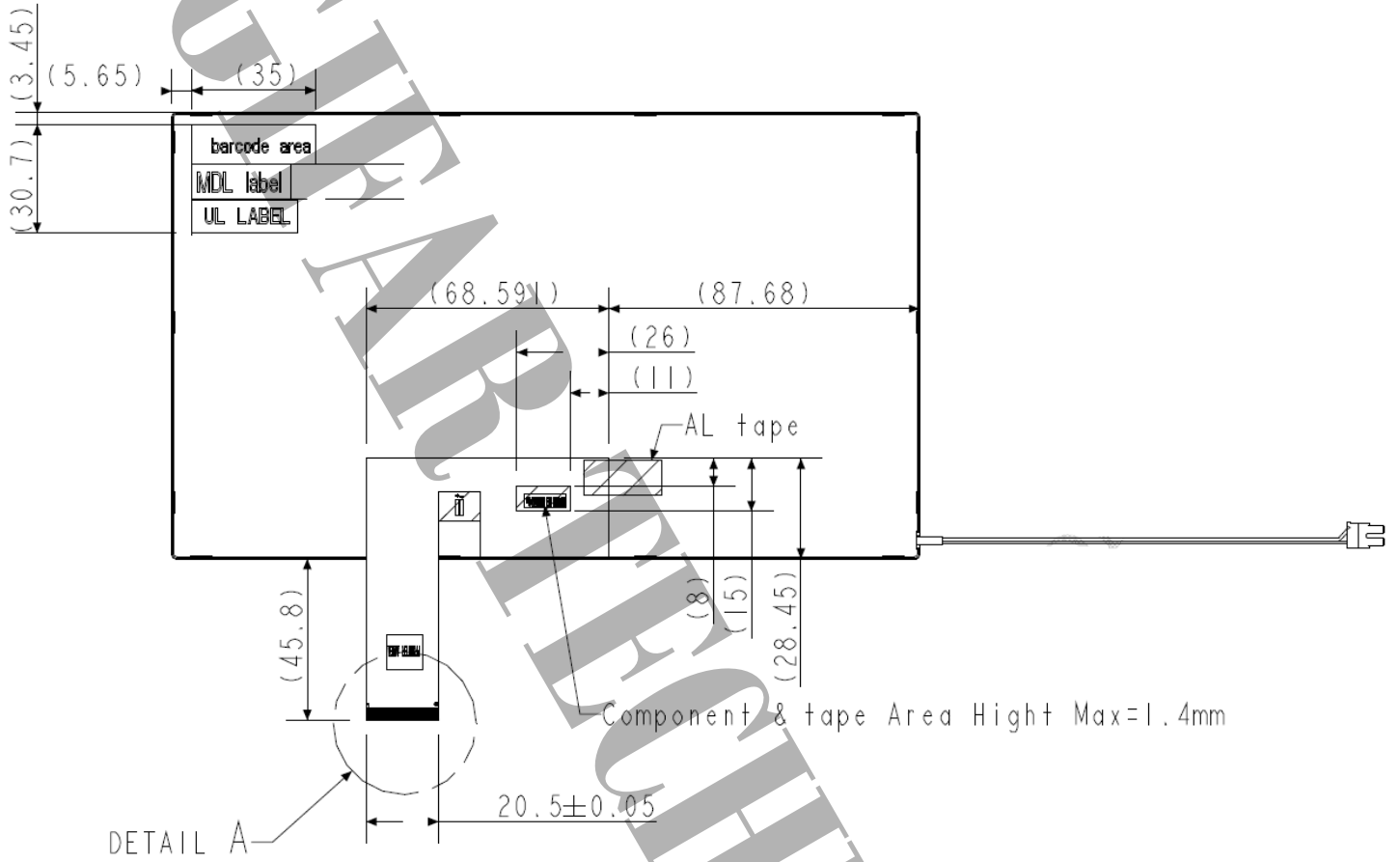

Remark :

- 1.General tolerance $\pm 0.3\text{mm}$
- 2.bending angel : minimum $R=0.4$ with 180 degrees
- 3.bending times : maxmun 3 times



7. OPTICAL CHARACTERISTICS

ITEM	SYMBOL	CONDITIONS	MIN	TYP	MAX	UNIT	NOTE	
Constrast Ratio	CR	Point-5	640	800		--	1, 2, 3	
Luminance(CEN)	Lw	Point-5	400	500		cd/m ²	1, 3	
Luminance Uniformity	ΔL		70	80		%	1, 3	
Response Time (White - Black)	Tr +Tf	Point-5	-	25	40	ms	1, 3, 5	
NTSC	-	Point-5	45	50	-	%	1, 3	
Viewing Angle	Horizontal	Left(ϕ)	CR \geq 10 Point-5	60	70	--	$^{\circ}$	1, 3
		Right(ϕ)		60	70	--	$^{\circ}$	
	Vertical	Upper(θ)		40	50	--	$^{\circ}$	1, 2, 4
		Down(θ)		60	70	--	$^{\circ}$	
Color Coordinate	White	Wx	Point-5	0.264	0.304	0.344	--	1, 3
		Wy		0.295	0.335	0.375		
	Red	Rx		0.540	0.580	0.620		
		Ry		0.297	0.337	0.377		
Green	Gx	0.289	0.329	0.369				
	Gy	0.577	0.617	0.657				
Blue	Bx	0.104	0.154	0.194				
	By	0.064	0.104	0.144				

Note1 : Measure condition: 25°C \pm 2°C, 60 \pm 10%RH, under 1 Lux in the dark room. BM-5A (TOPCON), viewing angle 2°, IL=260 mA (Backlight current) , measurement after lighting on 10 mins.

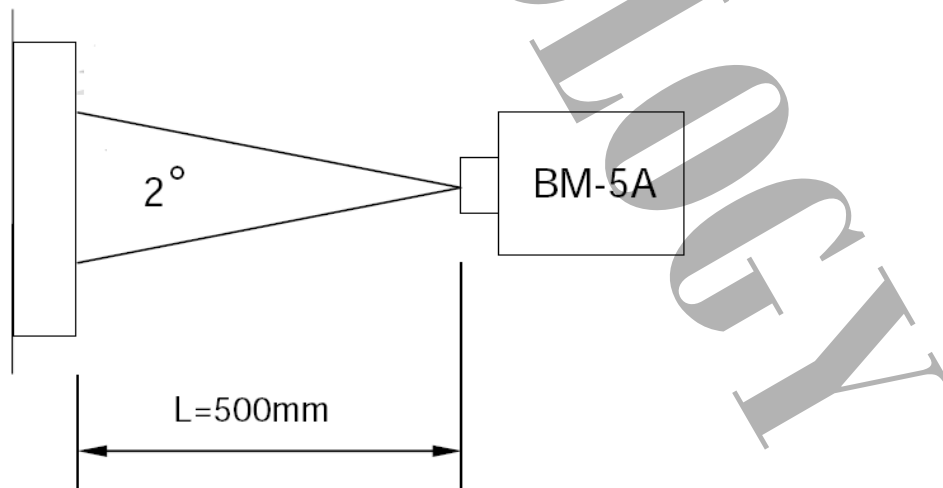

Note2 : Definition of contrast ratio :

$$\text{Contrast Ratio (CR)} = (\text{White}) \text{ Luminance of ON} \div (\text{Black}) \text{ Luminance of OFF}$$



Note3 : Definition of luminance : Measure white luminance on the point 5 as figure.7-1
 Definition of Luminance Uniformity: Measure white luminance on the point1-9 as figure.7-1
 $\Delta L = [L(\text{MIN})/L(\text{MAX})] \times 100$

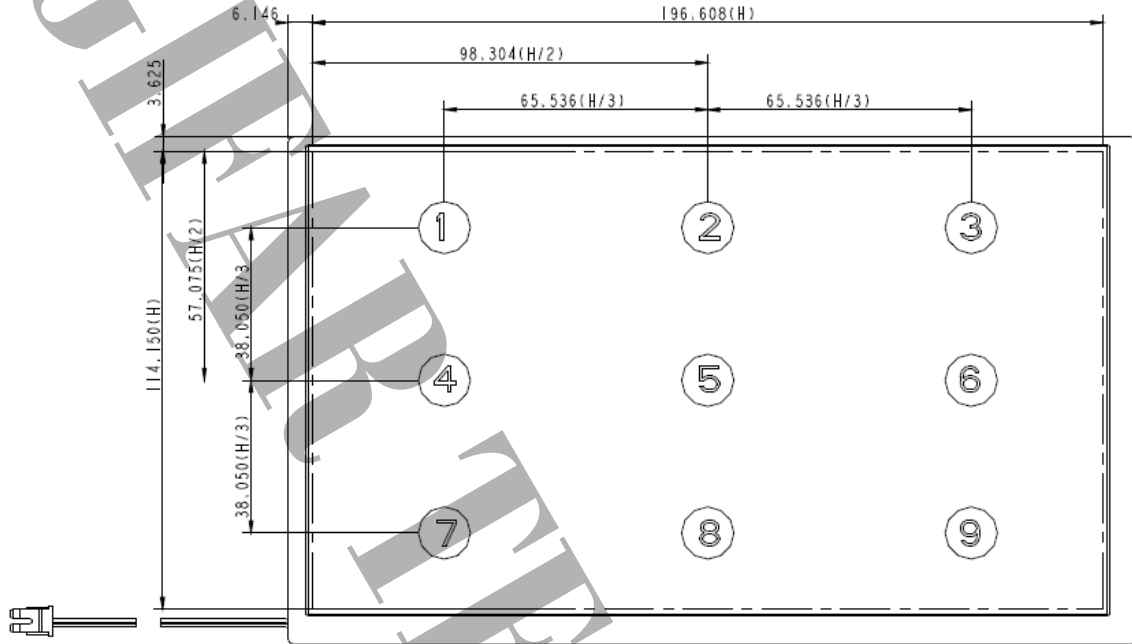

Fig.7-1 Measuring point

Note 4 : Definition of Viewing Angle(θ, ψ), refer to Fig.7-2 as below :

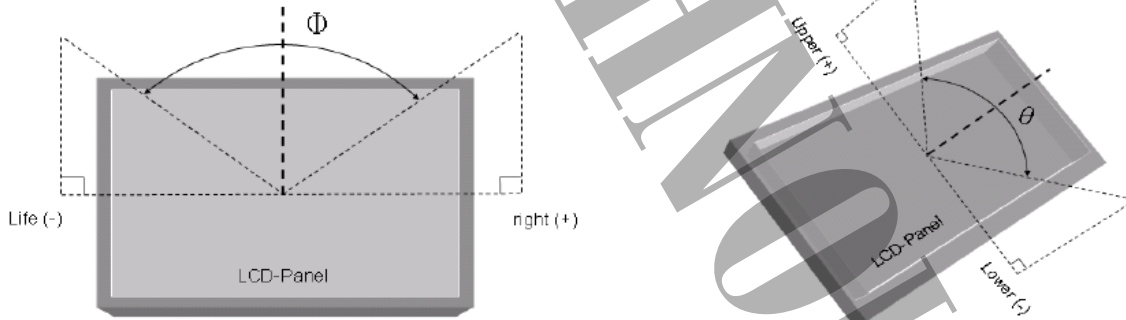

Fig.7-2 Definition of Viewing Angle

Note5 : Definition of Response Time.(White-Black)

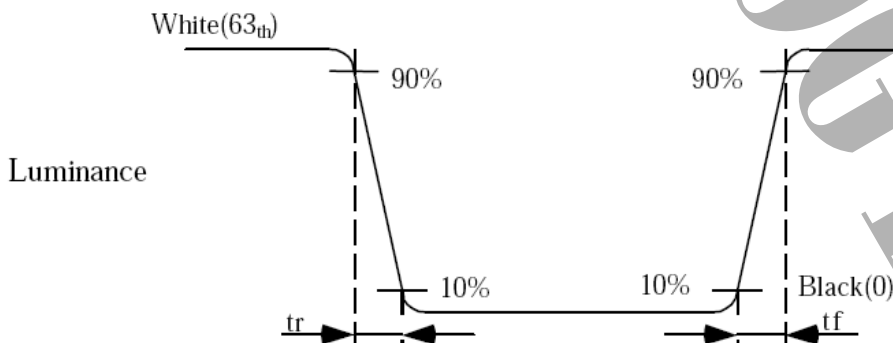

Fig.7-3 Definition of Response Time(White-Black)



8. RELIABILITY TEST

8.1. Temperature and humidity

TEST ITEMS	CONDITIONS	NOTE
High Temperature Operation	70°C ;240hrs	
High Temperature Operation	80°C _{TP} ; 240hrs	Note1
High Temperature Storage	80°C ; 240hrs	
High Temperature High Humidity Operation	60°C ; 90%RH ;240hrs	No condensation
Low Temperature Operation	-20°C ; 240hrs	Backlight unit always turn on
Low Temperature Storage	-30°C ; 240hrs	
Thermal Shock	-20°C (0.5hr) ~ 70°C (0.5hr) ; 100 Cycles	Non-Operating
Image Sticking	25°C ; 4hrs	

Note 1: Tp: panel surface temperature overall.

Note 2: Condition of Image Sticking test : 25 °C ± 2 °C
Operation with test pattern sustained for 4 hrs, then change to gray pattern immediately.
After 5 mins, the mura must be disappeared completely .

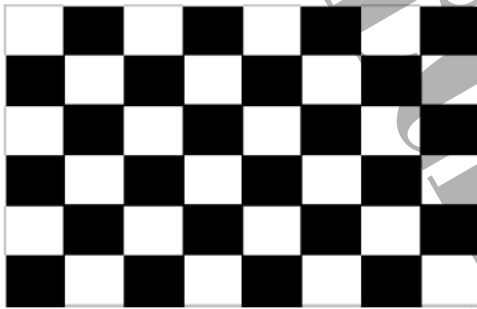

Image Sticking -pattern



Mid-Gray pattern

8.2 Shock and Vibration

TEST ITEMS	CONDITIONS
Shock (Non-operation)	<ul style="list-style-type: none"> Shock level: 980m/s²(equal to 100G). Waveform: half sinusoidal wave,6ms. Number of shocks: one shock input in each direction of three mutually perpendicular axes for a total of three shock inputs.
Vibration (Non-operation)	<ul style="list-style-type: none"> Sin wave Vibration Frequency : 8~33.3Hz Stroke : 1.3 mm Sweep : 2.9G,33.3~400Hz Vibration : sin wave, per axis (both X,Z axis: 2hrs ,Y axis: 4hrs) Cycle time: 15 min.

8.3 Electrostatic Discharge

TEST ITEM	CONDITIONS	Note
ESD	150pF , 330Ω , ±8kV&±15kV air& contact test	1
	200pF , 0Ω , ±200V contact test	2

Note : Measure
1: LCD glass and metal bezel
2: IF connector pins



8.4. Judgment standard

The Judgment of the above test should be made as follow:

Pass: Normal display image and no line defect.

Partial transformation of the module parts should be ignored.

Fail: No display image, Function NG, or line defects.

9. WARRANTY

9.1 The period is within 12 months since the date of shipping out under normal using and storage conditions.

9.2 The warranty will be avoided in case of defect induced by customer