





# SPECIFICATIONS

**CUSTOMER** : \_\_\_\_\_  
**MODEL NO.** : **GFTO070BA8001280V**  
**VERSION** : **A**  
**DATE** : **2018.01.12**  
**CERTIFICATION** : **ROHS**  
**CUSTOMER SIGN** : \_\_\_\_\_

QA Approved By	Approved By	Prepared By	Prepared By
			

晶發科技股份有限公司  
GI FAR TECHNOLOGY CO.,LTD

新北市樹林區東豐街 81 號

No. 81, Dongfeng St, Shulin District, 23874, New Taipei City, Taiwan, R.O.C.

TEL: +886-2-8684-1188 FAX: +886-2-8684-8532



## Revision Record

Data(y/m/d)	Ver.	Description	Note	page
2018.01.12	A	NEW		



## Contents

1. OVERVIEW.....	4
2. ABSOLUTE MAXIMUM RATINGS .....	5
3. ELECTRICAL CHARACTERISTICS.....	6
4. CONNECTOR INTERFACE PIN & FUNCTION .....	10
5. INTERFACE TIMING CHART .....	12
6. BLOCK DIAGRAM .....	15
7. MECHANICAL DIMENSION .....	16
7.1. Front Side .....	16
7.2. Rear Side.....	17
8. OPTICAL CHARACTERISTICS.....	18
9. RELIABILITY TEST CONDITIONS.....	22
10. WARRANTY .....	22



## 1. OVERVIEW

GFTO070BA8001280V is 7" color TFT-LCD (Thin Film Transistor Liquid Crystal Display) module composed of LCD panel, LVDS driver ICs ,control circuit and LED backlight. By applying 6 bits +Hi-FRC digital data, 800×RGB (3) ×1280, 16.7M-color images are displayed on the 7" diagonal screen.

General specifications are summarized in the following table:

Item	Specification
Display Area	94.2(H)×150.72(V) (mm) (7-inch diagonal)
Number of Pixels	800 ×3(H)×1280 (V)
Pixel Pitch	0.11775(H)×0.11775(V) (mm)
Color Pixel Arrangement	RGB vertical stripe
Display Mode	Normally Black
Number of color	16.7M(6bits+Hi FRC)(LVDS)
Gamut	60%(Typ)
Optimum Viewing Angle	whole view
Response Time	25 ms (Typ)
Surface Treatment	AG 25% , Hardness: 3H
Viewing Angle(CR>10)	85° 、 85° / 85° 、 85° (Min.)
Brightness	450 cd/m <sup>2</sup> (central) (Typ)
Uniformity	9point: 75%(min),80 %(typ)
Consumption of Power	Panel: 0.63W (LCD Module Typical) BL: 2.428(W)(Max.)(w/o Driver)
Module Size	106.34 (H)×164.61 (V)×4.45 (D) (w/o fpc) (typ.)
Module Weight	126.8g (Max)

The LCD Products listed on this document are not suitable for use of aerospace equipment, submarine cable, and nuclear reactor control system and life support systems. If customers intend to use these LCD products for applications listed above or those not included in the "Standard" list as follows, please contact our sales in advance.

Standard : Computer, Office equipment, Communication equipment, Test and Measurement equipment, Machine tool, Industrial robot, Audio and Visual equipment, Other consumer products.



## 2. ABSOLUTE MAXIMUM RATINGS

The following are maximum value, which if exceeded, may cause faulty operation or damage to the unit. The following are maximum value, which if exceeded, may cause faulty operation or damage to the unit

ITEM	SYMBOL	MIN.	MAX.	UNIT	NOTE
LCD Power Voltage	VDD	-0.3	3.8	V	
	AVDD	-0.3	13.5	V	
	VON	-0.3	VOFF+40	V	
	VOFF	-20	0.3	V	
	VON-VOFF	12	40	V	
Operation Temperature	Top	-20	70	°C	*1).*2).*3).*4)
Storage Temperature	Tstg	-30	80	°C	*1).*2).*3)

### 【Note】

- \*1) The relative temperature and humidity range are as below sketch, 90%RH Max. ( $T_a \leq 40$ )
- \*2) The maximum wet bulb temperature  $\leq 39^\circ\text{C}$  ( $T_a > 40^\circ\text{C}$ ) and without dewing.
- \*3) If product in environment which over the definition of the relative temperature and humidity out of range too long, it will affect visual of LCD.
- \*4) If you operate LCD in normal temperature range, the center surface of panel should be under  $50^\circ\text{C}$ .
- \*5) Ifp Conditions : Pulse Width $\leq 10\text{msec}$  , Duty $\leq 1/10$ .



### 3. ELECTRICAL CHARACTERISTICS

#### (A) TFT LCD

Ta=25°C

ITEM	SYMBOL	MIN	TYP	MAX	UNIT	NOTE
Digital Power Supply Voltage For LCD	DVDD	3	3.3	3.6	V	Note4
Logic Input Voltage (LVDS:IN+,IN-)	VCM	1	1.2	1.4	V	Note1
	VID	200	-	600	mV	Note1
	VTH	-	-	100	mV	VCM=1.2V Note1
	VTL	-100	-	-	mV	
1 Data time	UI	-	tclk*1/7	-	tclk	Note3
LVDS clock to data skew	tskew	-	-	300	ps	Note3
input data eye width	teyew	1082	-	-	ps	Note3
Analog Power Supply Voltage	AVDD	11.880	12.080	12.280	V	Note4
Gate On Power Supply Voltage	VON	22.5	23.5	24.5	V	Note4
Gate Off Power Supply Voltage	VOFF	-6.6	-6.0	-5.4	V	Note4
Common Power Supply Voltage	VCOM	3.45	4.15	4.85	V	Note2
Logic Input Voltage	VIL	0.8*DVDD	-	DVDD	V	
	VIH	GND	-	0.2*DVDD	V	

#### (B) TFT LCD Current Consumption

ITEM	SYMBOL	MIN	TYP	MAX	UNIT	NOTE
Rush Current	Irush	-	-	2	A	Note6
Gate on power current	IVON		0.5	5	mA	Note5
Gate off power current	IVOFF		0.5	5	mA	Note5
Digital power current	IVDD		40	80	mA	Note5
Analog power current	IAVDD		90	150	mA	Note5



【Note1】 LVDS DC electrical characteristics

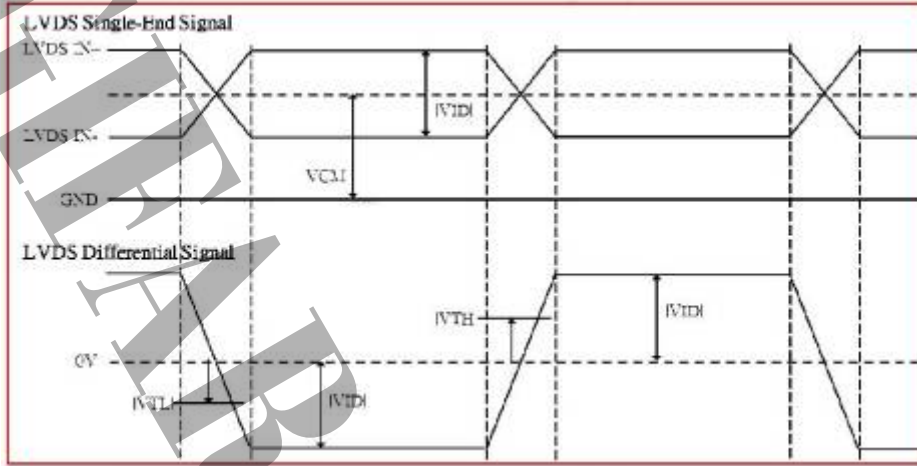

【Note2】  $V_{com}$  is supplied from FPCA, it could be adjusted by VR to make the flicker level be minimum

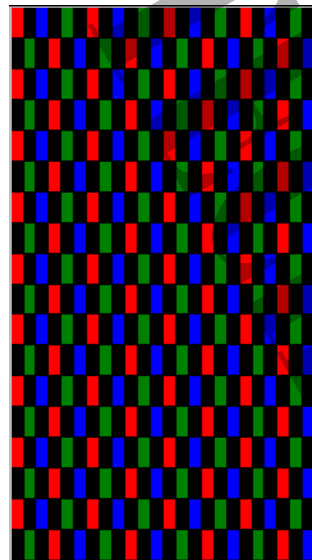

Flicker pattern

【Note3】 LVDS AC electrical characteristics

Differential LVDS signal : The following condition is base on operation frequency at 85MHz

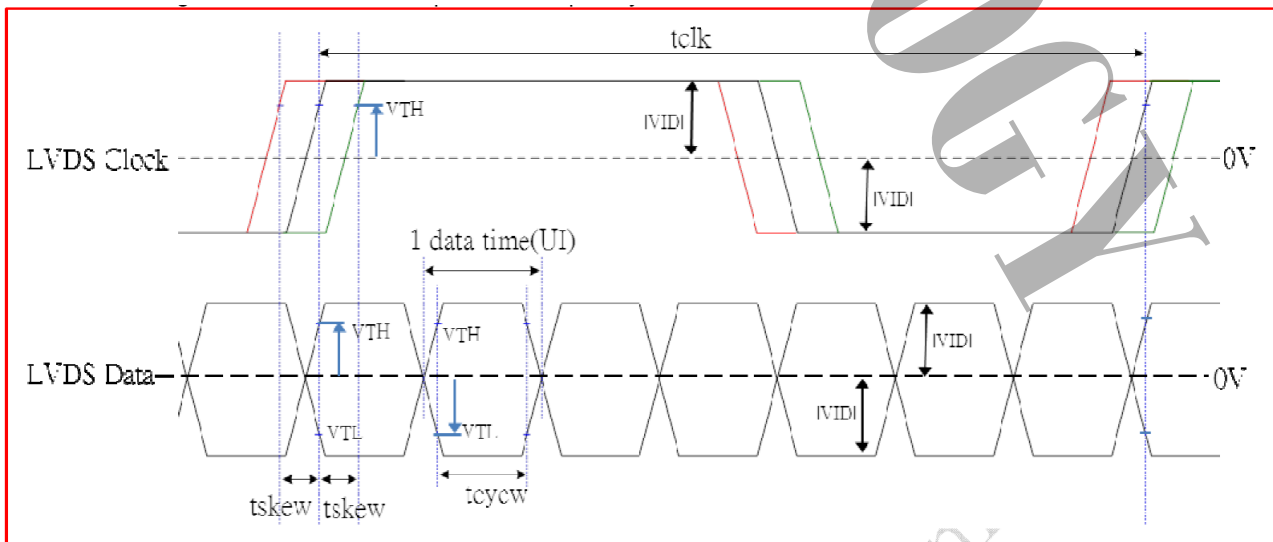



【Note4】

(1) POWER SEQUENCE

Power On : VDD→AVDD/VOFF→VON→Video & Logic Signal

Power Off : Video & Logic Signal→VON→AVDD/VGL→VDD

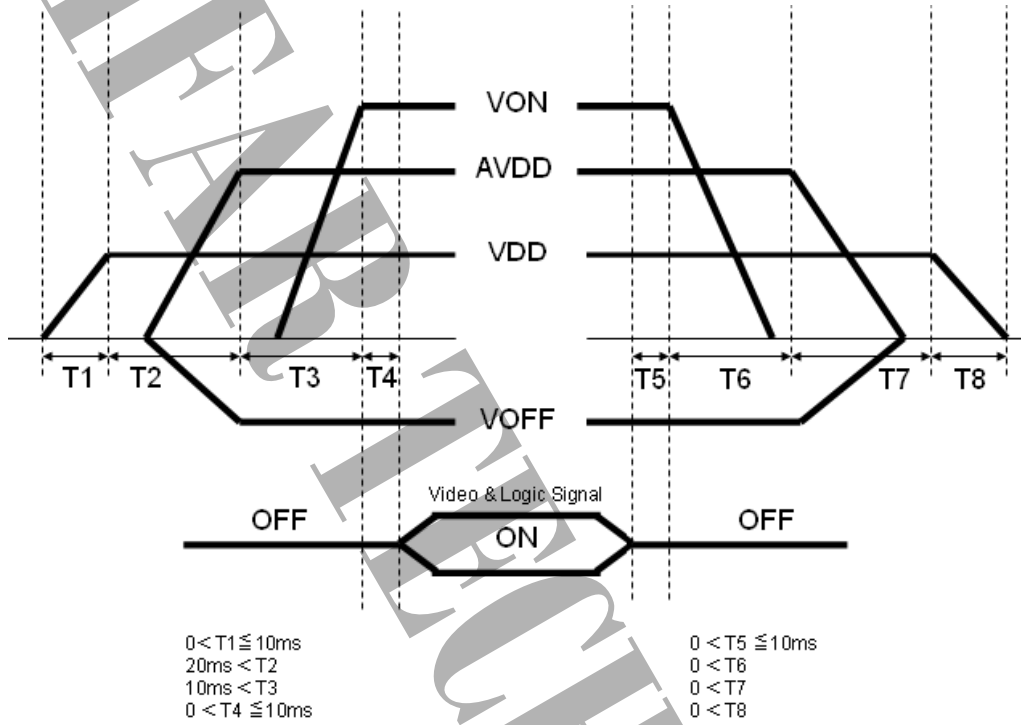

(2) Vin-dip state

(1) when  $3.0 > V_{in} \geq 2.7\text{V}$ ,  $t_d \leq 10\text{ms}$ .

(2) when  $V_{in} < 2.7\text{V}$ , Vin-dip condition should as the Vin-turn-off condition.

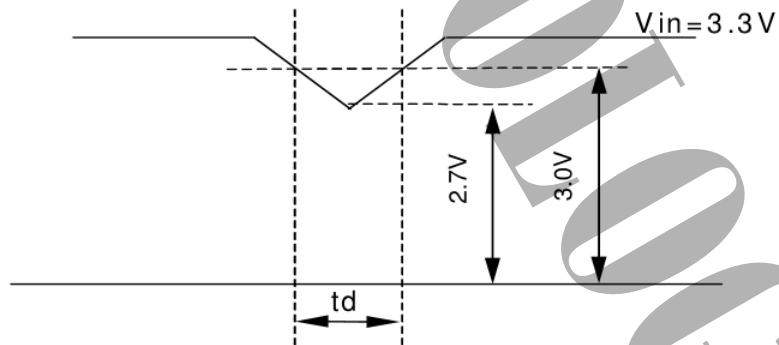

【Note5】 Typ. value is White Pattern : 1280 line mode

Circuit condition (Typ) :  $V_{DDI} = 3.3\text{V}$ ,  $f = 60\text{Hz}$ ,  $f = 77.28\text{kHz}$ ,  $f_{CLK} = 66.77\text{MHz}$







【Note6】 Irush measure condition

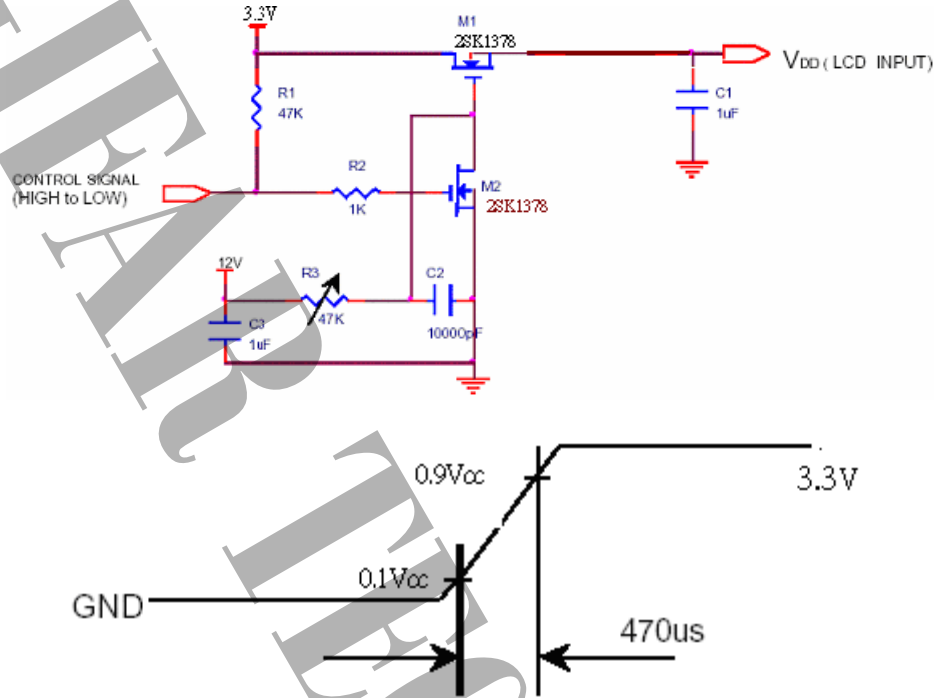

(C) Backlight

(a.) ELECTRICAL CHARACTERISTICS (Light Bar is arrayed for 7s \* 2 p)

Ta=25°C

ITEM	SYMBOL	MIN.	TYP.	MAX.	UNIT	NOTE
Forward Voltage	VF	2.85	3.0	3.4	V	
Forward Current	IF	-	51	-	mA	
Power consumption	PLED	-	2.142	-	W	*2)

(b.) LED LIFE-TIME

ITEM	SYMBOL	MIN.	TYP.	MAX.	UNIT	NOTE
LED Lifetime	Ta=25°C	30000	x	x	hrs	*3)

\*1) LED Circuit Diagram

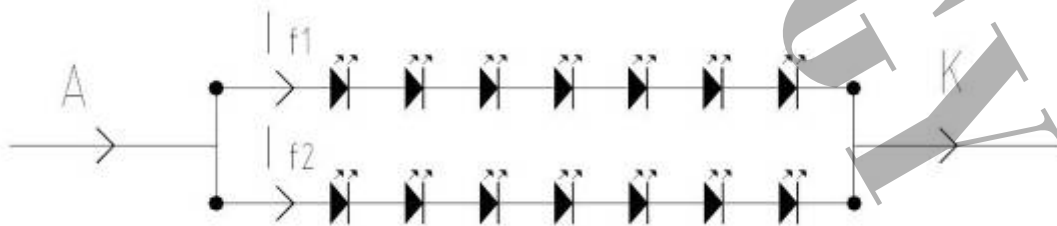

\*2) Calculator value for reference  $I_F \times V_F \times N = P_{LED}$

\*3) Life time means that estimated time to 50% degradation of initial luminous intensity.



## 4. CONNECTOR INTERFACE PIN & FUNCTION

CN (Interface signal)

Pin No.	SYMBOL	I/O	FUNCTION	NOTE
1	NC	---	Not connect (Test only)	
2	VDD	P	Digital power	
3	VDD	P	Digital power	
4	NC	---	Not connect (Test only)	
5	Rest	I	Global reset. Keep 3.3V+/-0.3V during operation. Normally pull high(High=3.3V+/-0.3V , Low=GND). (R=10K , C=1μF)	
6	STBYB	I	Standby mode control. Normally pull high. When STBYB=H, Normal operation. (Default) When STBYB=L, TCON and source driver are off and all output high(High=3.3V+/-0.3V_Low=GND).	
7	GND	P	Ground	
8	RXIN0-	I	Negative LVDS differential data inputs	
9	RXIN0+	I	Positive LVDS differential data inputs	
10	GND	P	Ground	
11	RXIN1-	I	Negative LVDS differential data inputs	
12	RXIN1+	I	Positive LVDS differential data inputs	
13	GND	P	Ground	
14	RXIN2-	I	Negative LVDS differential data inputs	
15	RXIN2+	I	Positive LVDS differential data inputs	
16	GND	P	Ground	
17	RXCLKIN-	I	Negative LVDS differential clock inputs	
18	RXCLKIN+	I	Positive LVDS differential clock inputs	
19	GND	P	Ground	
20	RXIN3-	I	Negative LVDS differential data inputs	
21	RXIN3+	I	Positive LVDS differential data inputs	
22	GND	P	Ground	
23	TP_SYNC	O	Sync signal for touch panel, keep floating if not used.	
24	NC	---	Not connect (Test only)	
25	GND	P	Ground	
26	NC	---	Not connect (Test only)	
27	NC	---	Not connect (Test only)	
28	NC	---	Not connect (Test only)	



29	AVDD	P	Power for Analog Circuit(AVDD = 12.080V±0.2V)	
30	GND	P	Ground	
31	LED-	P	LED Cathode	
32	LED-	P	LED Cathode	
33	L/R	---	Left/right selection (High= 1.8V±0.1V)Normally pull high	NOTE 1
34	U/D	---	Up/down selection (High= 1.8V±0.1V)Normally pull high	NOTE 1
35	VOFF	P	Negative power for TFT(VOFF = -6.0V±0.6V)	
36	NC	---	Not connect (Test only)	
37	NC	---	Not connect (Test only)	
38	VON	P	Positive power for TFT(VON = -24.0V±1V)	
39	LED+	P	LED ANODE	
40	LED+	P	LED ANODE	

【Note1】 : Selection of scanning mode

Setting of scan control input		Scanning direction
U/D (Normally Pull high)	L/R (Normally Pull high)	
1.8V	1.8V	Up to down , left to right(Default)
GND	GND	Down to up , right to left
1.8V	GND	Up to down , right to left
GND	1.8V	Down to up , left to right

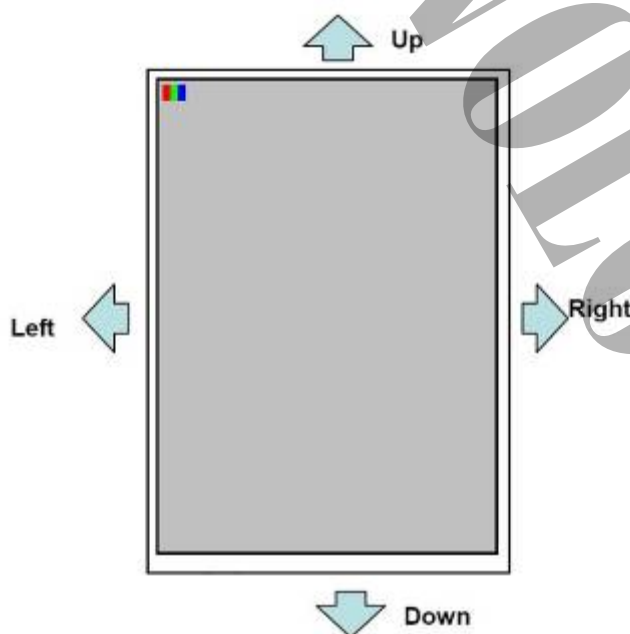



## 5. INTERFACE TIMING CHART

### (1)(a). LVDS input time sequence

Horizontal Sequence

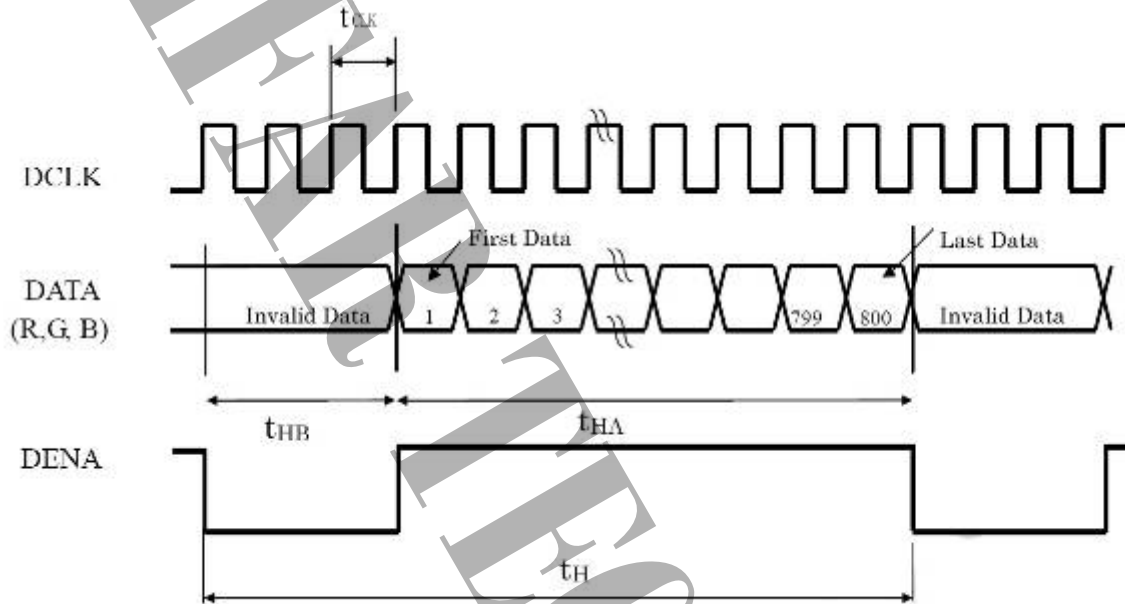

### (b) LCD input time sequence

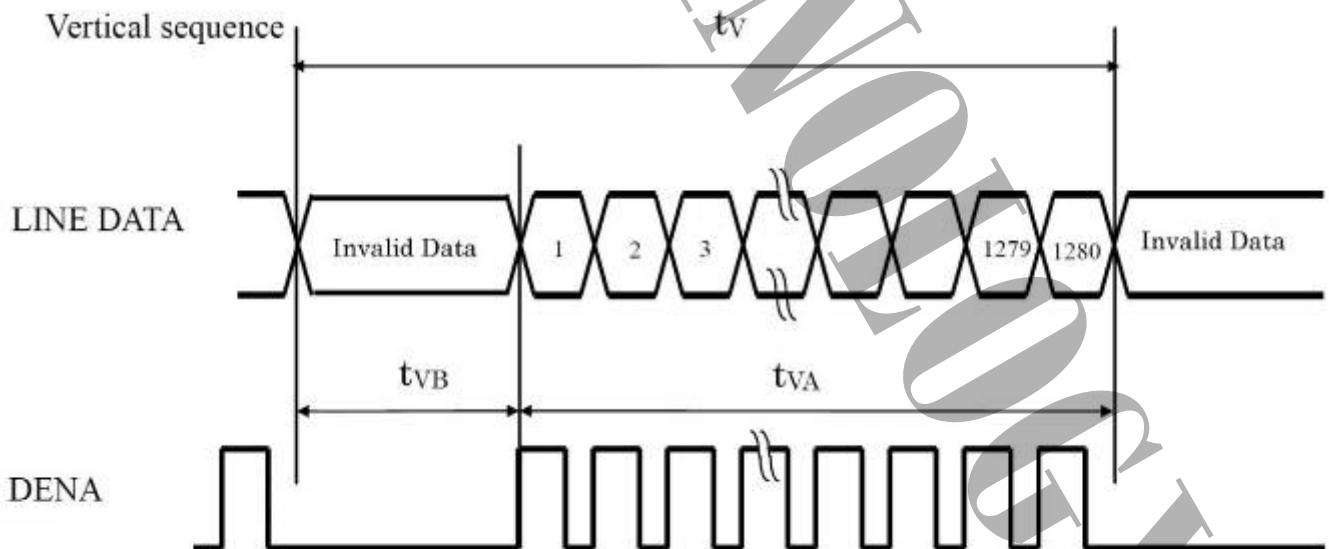



(C) LVDS Input Data mapping  
8 Bit LVDS input

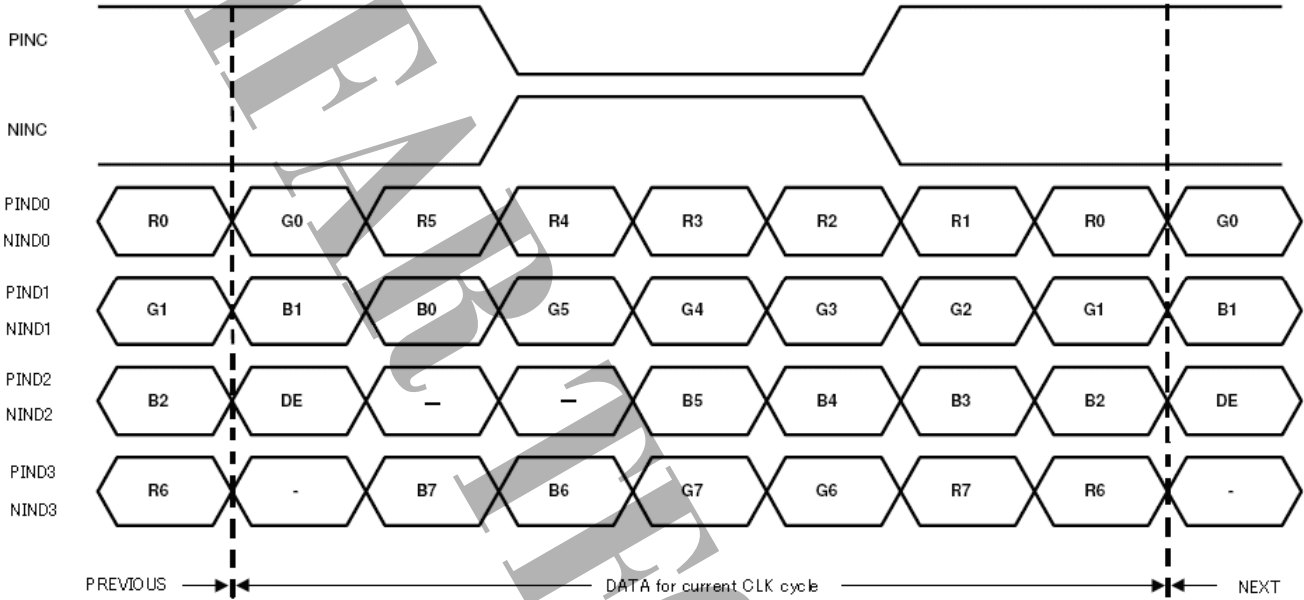

(2) Time Chart

ITEM			SYMBOL	MIN	TYP	MAX	UNIT	
LCD Timing	Frame Rate		-	60	60	60	Hz	
	DCLK		Frequency	$f_{CLK}$	66.3	66.8	85	MHz
	DENA	Horizontal	Horizontal total time	$t_H$	860	864	1026	$t_{CLK}$
			Horizontal Active time	$t_{HA}$	800	800	800	$t_{CLK}$
			Horizontal Blank time	$t_{HB}$	60	64	226	$t_{CLK}$
	DENA	Vertical	Vertical total time	$t_V$	1286	1288	1380	$t_H$
			Vertical Active time	$t_{VA}$	1280	1280	1280	$t_H$
			Vertical Blank time	$t_{VB}$	6	8	100	$t_H$

【Note】

- \*1) DENA (DATA ENABLE) usually is positive.
- \*2) During the whole blank period, DCLK should keep input.



(3) DATA mapping

COLOR	INPUT DATA	R DATA								G DATA								B DATA							
		R7	R6	R5	R4	R3	R2	R1	R0	G7	G6	G5	G4	G3	G2	G1	G0	B7	B6	B5	B4	B3	B2	B1	B0
		MSB							LSB	MSB							LSB	MSB							LSB
BASIC COLOR	BLACK	0	0	0	0	0	0	0	0	0	0	0	0	0	0	0	0	0	0	0	0	0	0	0	0
	RED(255)	1	1	1	1	1	1	1	1	0	0	0	0	0	0	0	0	0	0	0	0	0	0	0	0
	GREEN(255)	0	0	0	0	0	0	0	0	1	1	1	1	1	1	1	1	0	0	0	0	0	0	0	0
	BLUE(255)	0	0	0	0	0	0	0	0	0	0	0	0	0	0	0	0	1	1	1	1	1	1	1	1
	CYAN	0	0	0	0	0	0	0	0	1	1	1	1	1	1	1	1	1	1	1	1	1	1	1	1
	MAGENTA	1	1	1	1	1	1	1	1	0	0	0	0	0	0	0	0	1	1	1	1	1	1	1	1
	YELLOW	1	1	1	1	1	1	1	1	1	1	1	1	1	1	1	1	0	0	0	0	0	0	0	0
	WHITE	1	1	1	1	1	1	1	1	1	1	1	1	1	1	1	1	1	1	1	1	1	1	1	1
RED	RED(0)	0	0	0	0	0	0	0	0	0	0	0	0	0	0	0	0	0	0	0	0	0	0	0	0
	RED(1)	0	0	0	0	0	0	1	0	0	0	0	0	0	0	0	0	0	0	0	0	0	0	0	0
	RED(2)	0	0	0	0	0	0	1	0	0	0	0	0	0	0	0	0	0	0	0	0	0	0	0	0
	RED(254)	1	1	1	1	1	1	1	0	0	0	0	0	0	0	0	0	0	0	0	0	0	0	0	0
	RED(255)	1	1	1	1	1	1	1	1	0	0	0	0	0	0	0	0	0	0	0	0	0	0	0	0
GREEN	GREEN(0)	0	0	0	0	0	0	0	0	0	0	0	0	0	0	0	0	0	0	0	0	0	0	0	0
	GREEN(1)	0	0	0	0	0	0	0	0	0	0	0	0	0	0	1	0	0	0	0	0	0	0	0	0
	GREEN(2)	0	0	0	0	0	0	0	0	0	0	0	0	0	1	0	0	0	0	0	0	0	0	0	
	GREEN(254)	0	0	0	0	0	0	0	0	1	1	1	1	1	1	1	0	0	0	0	0	0	0	0	0
	GREEN(255)	0	0	0	0	0	0	0	0	1	1	1	1	1	1	1	0	0	0	0	0	0	0	0	
BLUE	BLUE(0)	0	0	0	0	0	0	0	0	0	0	0	0	0	0	0	0	0	0	0	0	0	0	0	0
	BLUE(1)	0	0	0	0	0	0	0	0	0	0	0	0	0	0	0	0	0	0	0	0	0	0	0	1
	BLUE(2)	0	0	0	0	0	0	0	0	0	0	0	0	0	0	0	0	0	0	0	0	0	0	1	0
	BLUE(254)	0	0	0	0	0	0	0	0	0	0	0	0	0	0	0	0	1	1	1	1	1	1	1	0
	BLUE(255)	0	0	0	0	0	0	0	0	0	0	0	0	0	0	0	0	1	1	1	1	1	1	1	1

【Note】

1. Gray level : Color (n): n means level of gray scale. Larger n means brighter level.
2. Data : 1= High, 0 = Low



## 6. BLOCK DIAGRAM

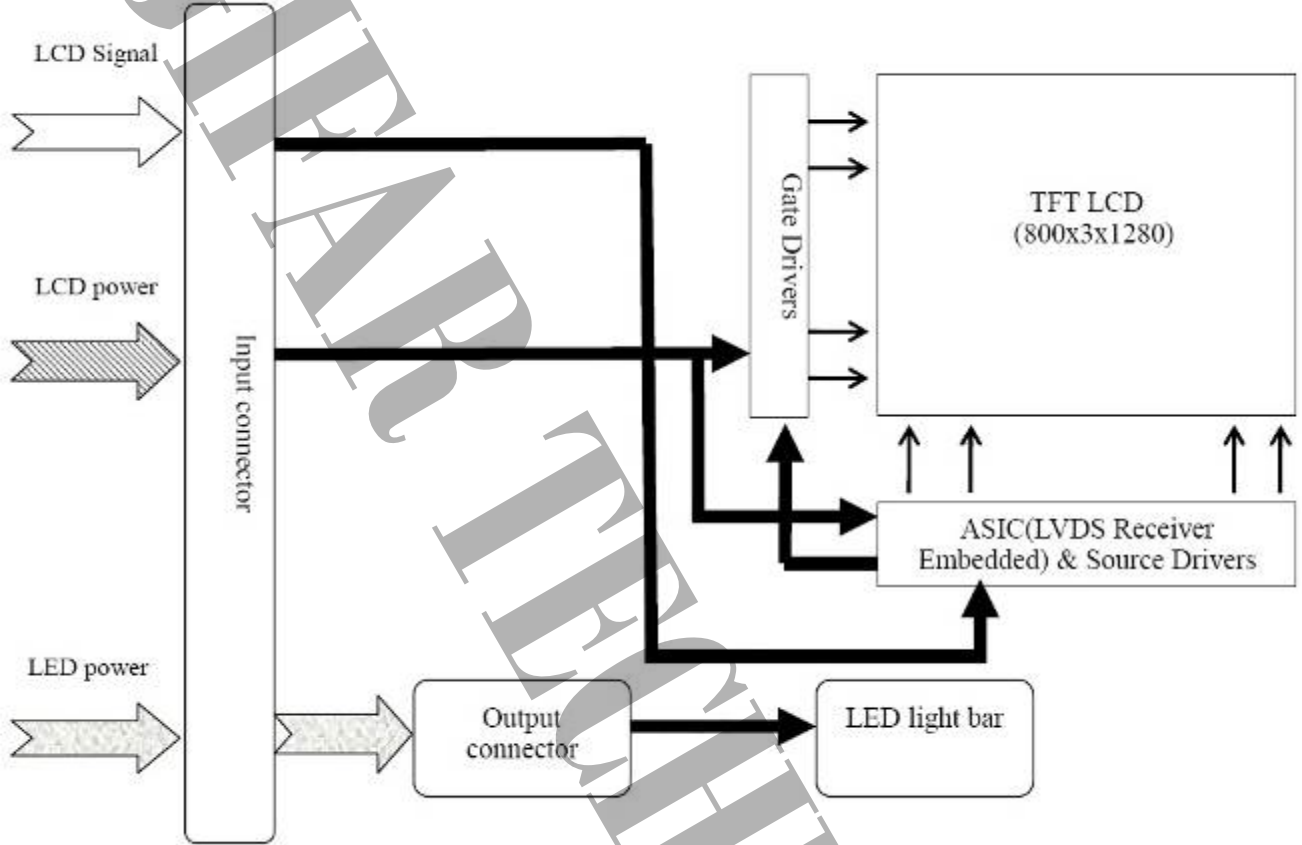



## 7. MECHANICAL DIMENSION

### 7.1 Front Side

The tolerance, not show in the figure, is  $\pm 0.3\text{mm}$ .

[Unit : mm]







### 7.2 Rear Side

The tolerance, not show in the figure, is  $\pm 0.3\text{mm}$ .

[Unit : mm]

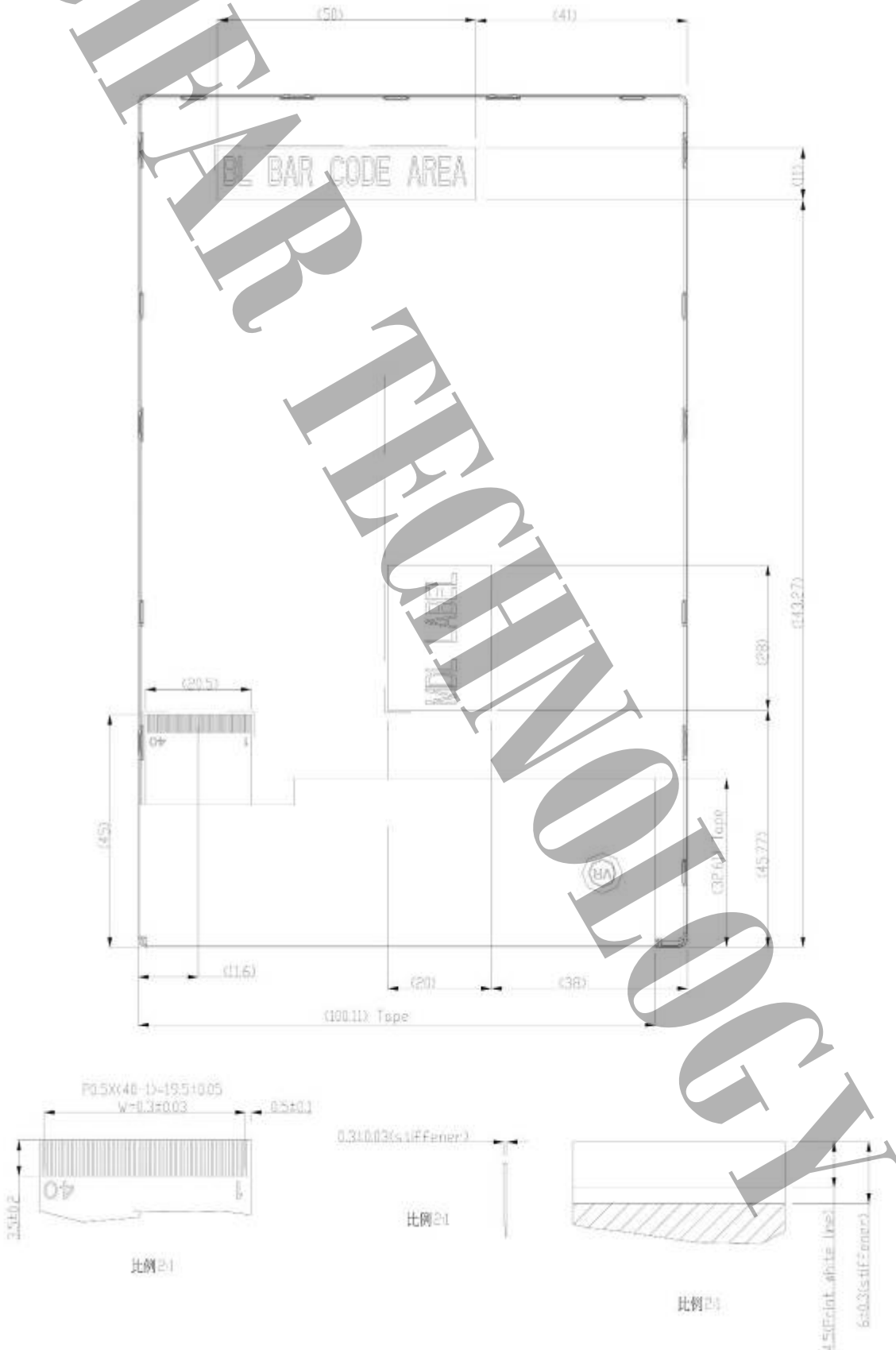

NOTE:



## 8. OPTICAL CHARACTERISITCS

Ta=25°C , VDD=3.3V

ITEM	SYMBOL	CONDITION	MIN.	TYP.	MAX.	UNIT	NOTE	
Contrast Ratio	CR	$\theta = \psi = 0^\circ$	600	800	--	--	*1) 2)	
Luminance (central)	L	$\theta = \psi = 0^\circ$	360	450	--	cd/m <sup>2</sup>	*1)	
Uniformity(9P)	$\Delta L$	$\theta = \psi = 0^\circ$	75	80	--	%	*1) 3)	
Response Time	Tr+Tf	$\theta = \psi = 0^\circ$	--	25	35	ms	*5)	
Cross talk	CT	$\theta = \psi = 0^\circ$	--	--	2	%	*6)	
View angle	Horizontal	$\psi$	CR ≥ 10	80/-80	85/-85	--	°	View angle
	Vertical	$\theta$		80/-80	85/-85	--	°	
Color Temperature Coordinate	W	X	$\theta = \psi = 0^\circ$	0.256	0.306	0.356	--	Based on: CPT BL
		Y		0.290	0.340	0.390		
	R	X		(0.597)	(0.647)	(0.697)	--	
		Y		(0.281)	(0.331)	(0.381)		
	G	X		(0.256)	(0.306)	(0.356)	--	
		Y		(0.506)	(0.556)	(0.606)		
	B	X		(0.103)	(0.153)	(0.203)	--	
		Y		(0.028)	(0.078)	(0.128)		
Gamut		$\theta = \psi = 0^\circ$	--	60	--	%		
Gamma	$\gamma$	GL	2.0	2.2	2.4	--	*7)	

Color coordinate and color gamut are measured by SRUL1R, response time is measured by TRD-100, and all the other items are measured by BM-5A (TOPCON). All these items are measured under the dark room condition (no ambient light).

Measurement Condition: IL=51 mA(each LED)

Definition of these measurement items is as follows:

\*1) Setup of Measurement Equipment

The LCD module should be turn-on to a stable luminance level to be reached. The measurement should be executed after lighting Backlight for 20 minutes and in a dark room.

\*2) Definition of Contrast Ratio

CR=ON (White) Luminance/OFF (Black) Luminance

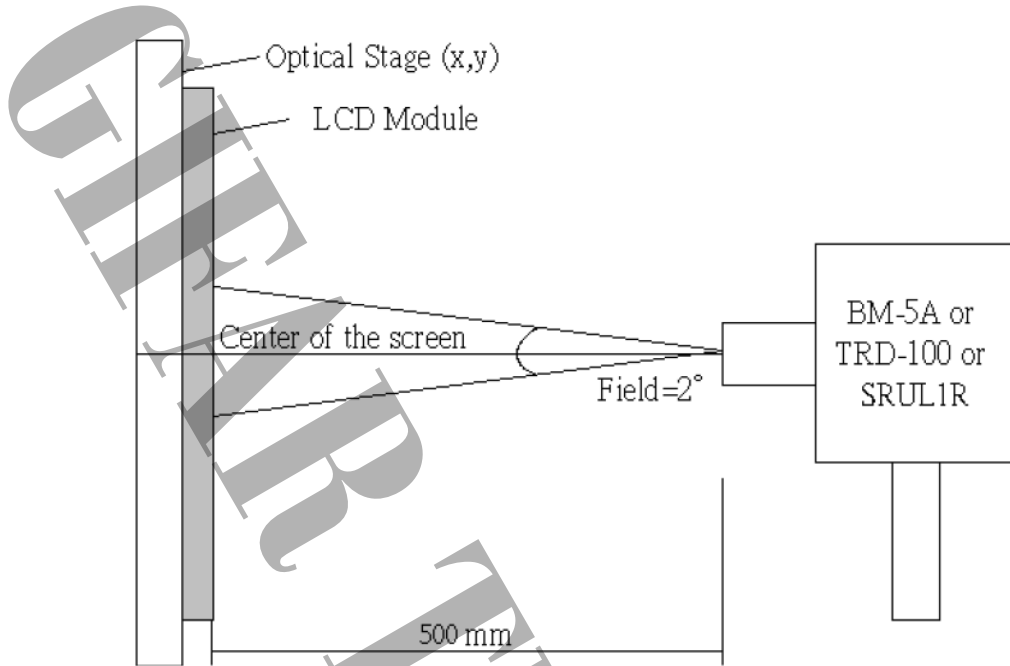

\*3) Definition of Luminance and Luminance uniformity

Central luminance: The white luminance is measured at the center position "5" on the screen, see Fig below.

5P Luminance (AVG): The white luminance is measured at measuring points 1、3、5、7、9 see Fig below.

9P Uniformity:  $D L = (L_{min} / L_{max}) \times 100\%$  at measuring points 1 ~ 9 see fig below

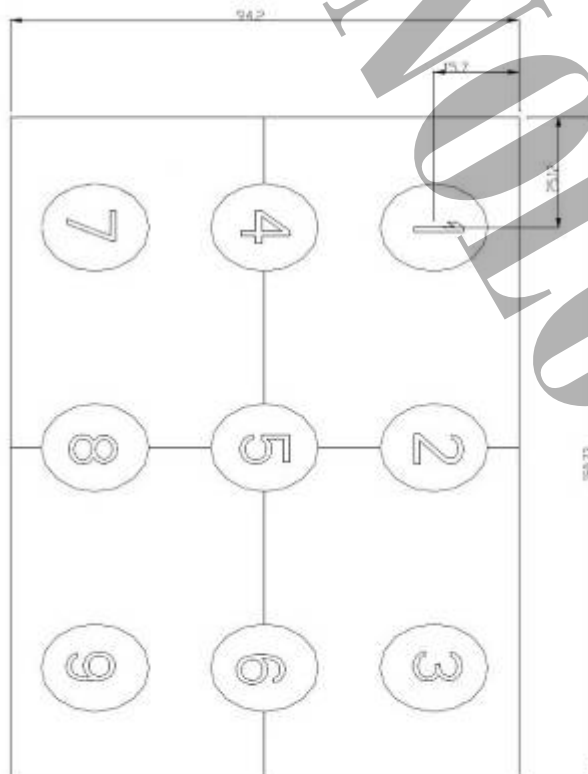



\*4) Definition of view angle( $\theta$  ,  $\Psi$ )

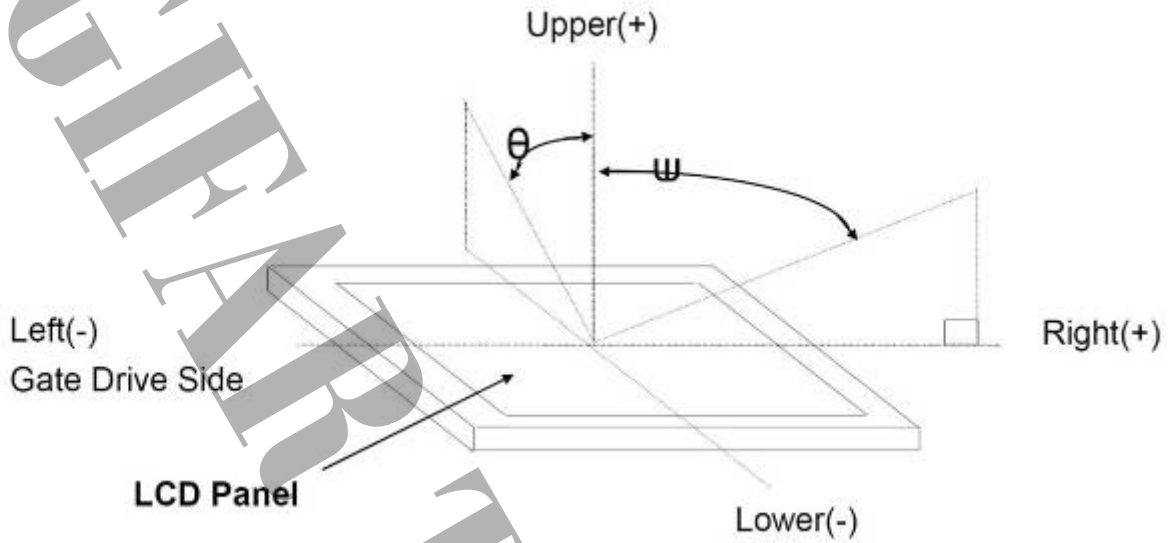

\*5) Definition of response time

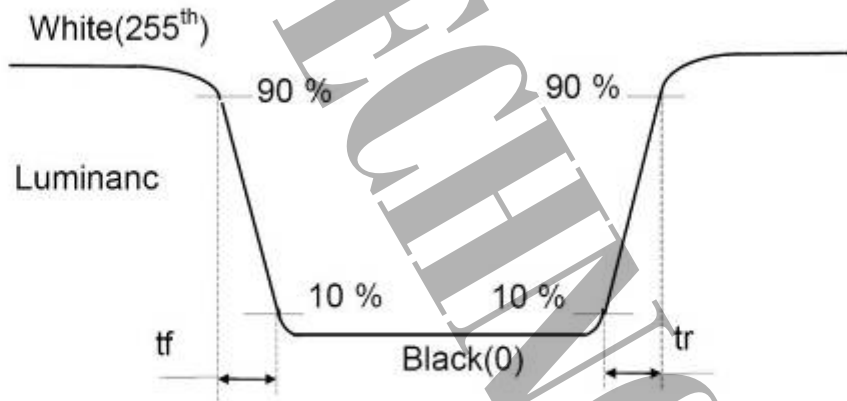

\*6) Crosstalk Modulation Ratio:

$$CT = | Y_B - Y_A | / Y_{A, \text{max}} \times 100\%$$

$Y_A$  ,  $Y_B$  measure position and definition

$Y_A$  means luminance at gray level 128(exclude gray level 0 pattern)

$Y_B$  means luminance at gray level 128(include gray level 0 pattern)





\*7) Definition Gamma (VESA)

Based on Customer Sample, take the average value as a standard center value and the variation range of gamma value caused by loop voltage error should be between +/- 0.2. the bellow figure shows how to obtain the gamma curve and  $\gamma$  (from gray level: 0、15、31---239、255).

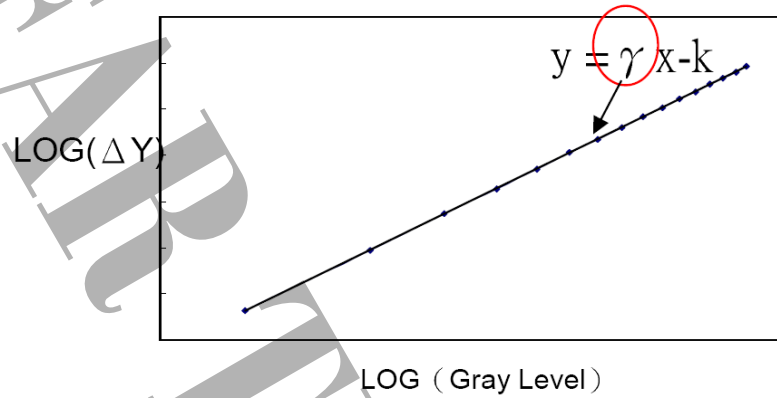



## 9. RELIABILITY TEST CONDITIONS

Test Items	Conditions
High Temp. Operating Test	70°C, 240 Hrs
High Temp. Storage Test	80°C, 240 Hrs
High Temp/ High Humidity Operating Test	60°C, 90% RH, 240Hrs
High Temp./High Humidity Storage Test	60°C, 90% RH, 240Hrs
Low Temp. Operating Test	-20°C, 240 Hrs
Low Temp. Storage Test	-30°C, 240 Hrs
Thermal shock	-30°C (0.5 Hr)~80°C (0.5 Hr) ,200 Cycles
Shock Test	980m/s <sup>2</sup> ,Action time: 6ms, Time: 1 times for each direction, Direction:+/-X, +/-Y, +/-Z
Vibration Test	Sin wave Vibration, Frequency : 8~33.3Hz Stoke : 1.3 mm ,Vibration : sin wave, per axis (both X,Z axis: 2hrs ,Y axis: 4hrs), Sweep : 2.9G, 33.3 Hz -400 Hz, Cycle time: 15 min.
ESD (Power off)	a. 【MM Connector】 200 pF, 0 Ω , ±200 V, once for each terminal b. 【HM Air】 150 pF, 330 Ω , ±15 kv, 25 times/point, 4 points/panel c. 【HM Contact】 150 pF, 330 Ω , ±15 kv, 25 times/point, 4 points/panel

(Note)

The judgment of the above test should be made as follow:

Pass : Normal display image with no obvious non-uniformity and no line defect.

Partial transformation of the module parts should be ignored.

Fail : No display image, obvious non-uniformity, or line defects.

## 10. WARRANTY

1. The period is within 12 months since the date of shipping out under normal using and storage conditions.
2. The warranty will be avoided in case of defect induced by customer.