





SPECIFICATIONS

CUSTOMER : _____
MODEL NO. : GFTO070DA1024600V
VERSION : A
DATE : 2018.01.10
CERTIFICATION : ROHS
CUSTOMER SIGN : _____

QA Approved By	Approved By	Prepared By	Prepared By
			

晶發科技股份有限公司
GI FAR TECHNOLOGY CO.,LTD

新北市樹林區東豐街 81 號

No. 81, Dongfeng St, Shulin District, 23874, New Taipei City, Taiwan, R.O.C.

TEL: +886-2-8684-1188 FAX: +886-2-8684-8532



Revision Record

Data(y/m/d)	Ver.	Description	Note	page
2018.01.10	A	NEW		



Contents

1. OVERVIEW.....	4
2. ABSOLUTE MAXIMUM RATINGS	5
3. ELECTRICAL CHARACTERISTICS.....	6
3.1. Typical Operation Conditions.....	6
3.2. Current Consumption.....	7
3.3. Power 、 Signal Sequence	7
3.4. Backlight.....	8
4. INTERFACE CONNECTION	9
4.1. CN1 (Input Signal)	9
4.2. CN2 (backlight)	10
5. INPUT SIGNAL(DE ONLY MODE)	11
5.1 Timing Specification	11
5.2 Timing sequence(Timing chart)	11
6. MECHANICAL DIMENSION.....	14
6.1. Front Side	14
6.2. Rear Side.....	15
7. OPTICAL CHARACTERISTICS.....	17
8. RELIABILITY TEST.....	18
8.1. Temperature And Humidity.....	18
8.2. Shock & Vibration.....	18
8.3 Electrostatic Discharge.....	19
8.4 Judgment Standard	19
9. PACKING	20
10. WARRANTY	20



1. OVERVIEW

GFTO070DA1024600V is 7" color TFT-LCD (Thin Film Transistor Liquid Crystal Display) module composed of LCD panel, driver ICs, control circuit and LED backlight. By applying 1024×600 images are displayed on the 7" diagonal screen. Display 16.7M colors by R.G.B signal input.

General specifications are summarized in the following table:

Item	Specification			
Display Area (mm)	154.2144(H) × 85.92(V)			
Number of Pixels	1024(H) × 3(RGB) × 600(V)			
Pixel Pitch(mm)	0.1506(H) × 0.1432(V)			
Color Pixel Arrangement	RGB vertical stripe			
Display Mode	Normally White			
Number of color	16.7M			
Brightness (cd/m ²)	600nit(typ)			
Response Time (ms)	25ms(typ.)			
Contrast Ratio	800:1			
Viewing Angle (CR > 10)	160 degree (Horizontal) , 130 degree(Vertical)			
Color Saturation	50%(typ.)			
Optimum Viewing Direction	6 O'clock (Max. contrast ratio, Gray level inversion)			
Power Consumption(W)	2.592			
Interface connection	LVDS, 40pin			
Module Size (mm)		Min.	Typ.	Max
	Horizontal (H)	164.6	164.9	165.2
	Vertical (V)	99.7	100	100.3
	Depth (D)	5.4	5.7	6.0
Module Weight (g)	150g(typ.)			
Backlight	LED			
Surface Treatment	Anti-Glare, 3H			



2. ABSOLUTE MAXIMUM RATINGS

The following are maximum values which, if exceeded, may cause faulty operation or damage to the unit.

Item	Symbol	Min.	Max.	Unit	Note
Digital Supply Voltage	DVDD	-0.3	+3.96	V	
Analog Supply Voltage	AVDD	-0.5	+14.85	V	
Gate On Voltage	VGH	-0.3	+40	V	
Gate Off Voltage	VGL	-20	+0.3	V	
Gate On-Gate Off Voltage	VGH-VGL	12	40	V	
Signal Input Voltage	NIND0 ~ NIND3 PIND0 ~ PIND3 NINC, PINC	-0.5	5	V	
Forward Current (per LED)	I _f	-	30	mA	
Reverse Voltage (per LED)	V _R	-	5	V	
Pulse forward current (per LED)	I _{fp}	-	100	mA	Note *2)
Operation Temperature (LCD panel surface overall)	T _{op1}	-20	80	°C	Note *1)
Operation Temperature	T _{op}	-20	70	°C	Note *1)
Storage Temperature	T _{stg}	-30	80	°C	Note *1)

Note :

- *1) If the product were used out of the operation and storage range, it will have quality issue.
- *2) I_{fp} Conditions : Pulse Width ≤ 10msec , Duty ≤ 1/10.
- *3) Each one of LED operation must be follow diagram of Ambient Temperature and Allowable Forward Current.

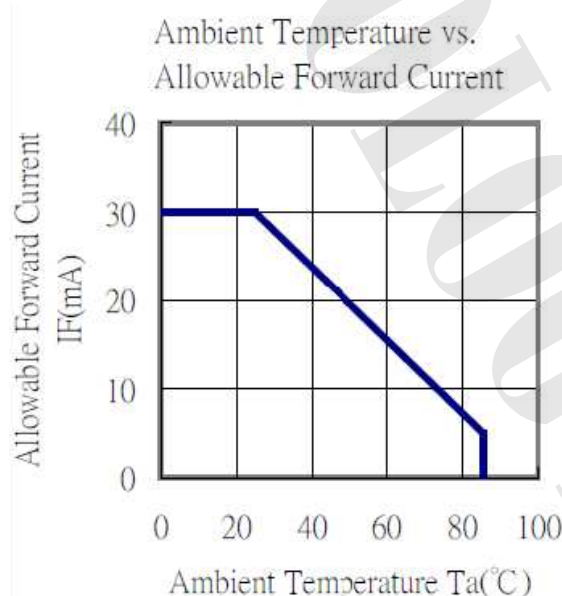

- *4) If users use the product out off the environmental operation range (temperature and humidity) , it will have visual quality concerns.



3. ELECTRICAL CHARACTERISTICS

3.1 Typical Operation Conditions

Ta=25°C

Item	Symbol	Min.	Typ.	Max.	Unit	Note
Digital Supply Voltage	DVDD	3	3.3	3.6	V	
Logic Input Voltage (LVDS:IN+,IN-)	VCM	$\frac{ VID }{2}$	-	$2.4 \cdot \frac{ VID }{2}$	V	Note1
	VID	200	-	600	mV	Note1
	VTL	-	-	100	mV	VCM=1.2V Note1
	VTL	-100	-	-	mV	Note1
Analog Power Supply Voltage	AVDD	9.4	9.6	9.8	V	
Gate On Power Supply Voltage	VGH	17	18	19	V	
Gate Off Power Supply Voltage	VGL	-6.6	-6	-5.4	V	
Common Power Supply Voltage	VCOM	3.7	3.9	4.1	V	Note2
Logic Input Voltage	VIL	0.7*DVDD	-	DVDD	V	
	VIH	GND	-	0.3*DVDD	V	

Note1 : LVDS signal

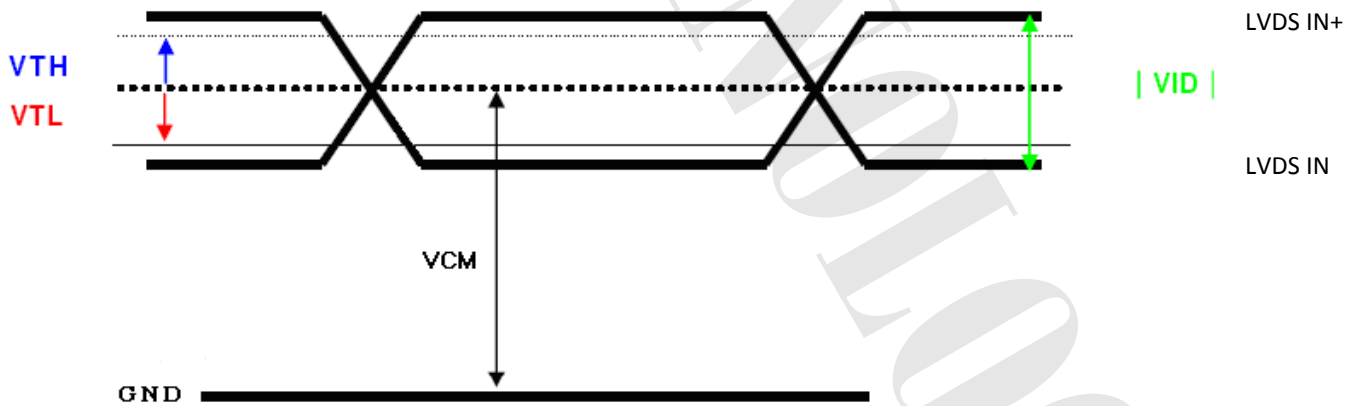

Note2 : Vcom is the reference voltage for customer, it should be adjust VCOM to make the flicker level be minimum



3.2 Current Consumption

Item	Symbol	Conditions	Min.	Typ.	Max.	Unit	Note
Gate on Power Current	IVGH	VGH = 18V	-	0.5	1	mA	Note1
Gate off Power Current	IVGL	VGL = -6V	-	0.5	1	mA	Note1
Digital Power Current	IDVDD	VDD = 3.3V	-	30	45	mA	Note1
Analog Power Current	IAVDD	AVDD = 9.6V	-	35	45	mA	Note1
Total Power Consumption	PC		-	447	604	mW	Note1

Note1 : Typical: Under 256 gray pattern

Maximum: Under black pattern



256 Gray Pattern

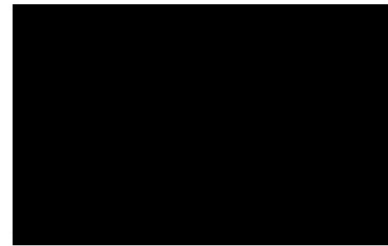

Black Pattern

3.3 Power 、Signal sequence

Power On : DVDD → AVDD/VGL → VGH → Video & Logic Signal → Backlight

Power Off : Backlight → Video & Logic Signal → VGH → AVDD/VGL → DVDD

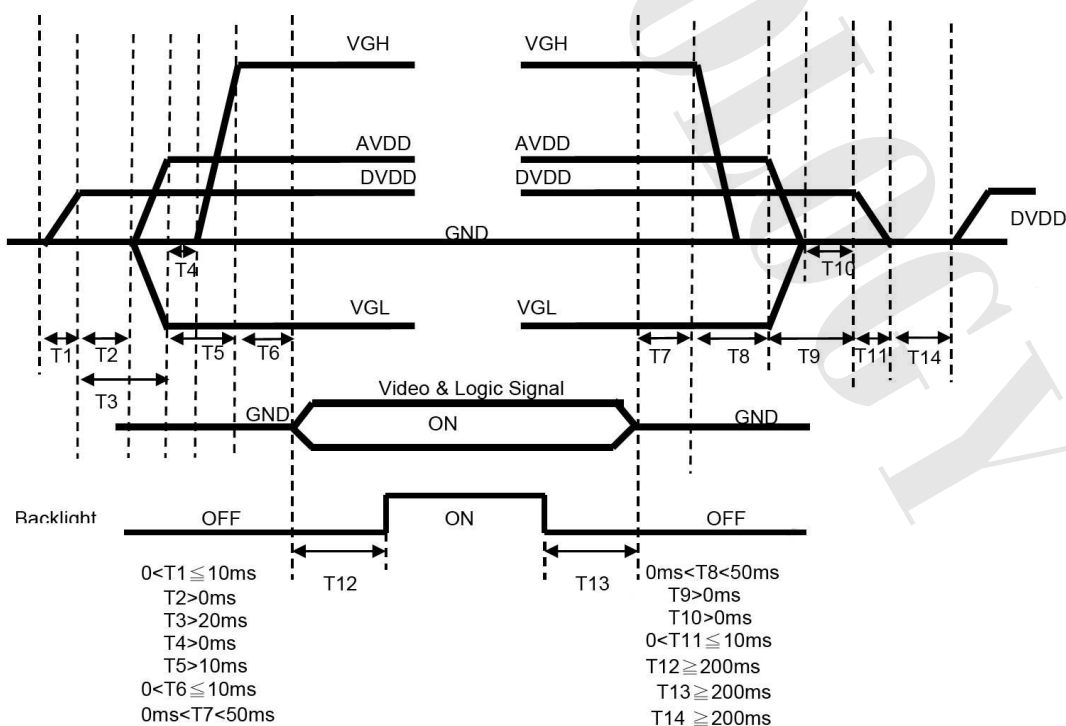



3.4 Backlight

Ta=25°C

Item	Symbol	Conditions	Min.	Typ.	Max.	Unit	NOTE
LED Current	IL	Ta=25°C Each serial=20mA	-	220	-	mA	
LED Voltage	VL	Ta=25°C Each serial=20mA	8.7	9.75	10.8	V	
Power consumption	WL	V Ta=25°C Each serial=20mA	-	2.145	-	W	
LED Lifetime	-	Ta=25°C Each serial=20mA	30000			Hr	

Note :

*1) LED Circuit Diagram

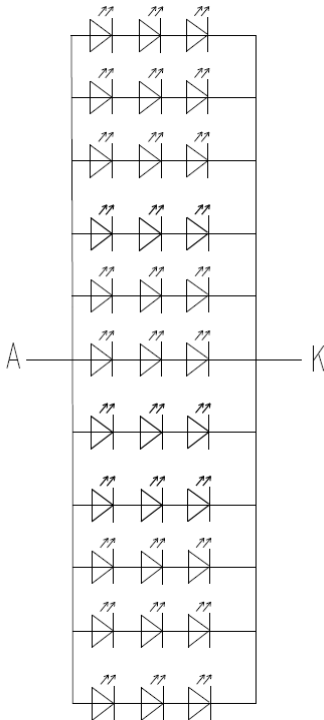

*2) A : Anode(+) , K : Cathode(-)

*3) Suggestion: Using the constant current control to avoid the leakage light and brightness quality issue.

*4) Definition of Led lifetime : Luminance < Initial luminance 50%..



4. INTERFACE CONNECTION

4.1 CN1 (Input Signal)

Pin NO.	SYMBOL	DESCRIPTION
1	VCOM	Common voltage
2	DVDD	Digital Power
3	DVDD	Digital Power
4	NC	Not connect
5	RESET	Global reset pin. Active low to enter reset state. Suggest to connecting with an RC reset circuit for stability. Normally pull high. (R=10KΩ , C=1μF)
6	UPDN	Vertical inversion
7	SHLR	Horizontal inversion
8	STBYB	Standby mode, normally pull high STBYB="1", normal operation STBYB="0", timing control, source driver will turn off, all output are high-Z
9	GND	Ground
10	NINC	Negative LVDS differential clock input
11	PINC	Positive LVDS differential clock input
12	GND	Ground
13	NIND0	Negative LVDS differential clock input
14	PIND0	Positive LVDS differential clock input
15	GND	Ground
16	NIND1	Negative LVDS differential clock input
17	PIND1	Positive LVDS differential clock input
18	GND	Ground
19	NIND2	Negative LVDS differential clock input
20	PIND2	Positive LVDS differential clock input
21	GND	Ground
22	NIND3	Negative LVDS differential clock input
23	PIND3	Positive LVDS differential clock input
24	GND	Ground
25	SELB	6bit/8bit mode select if LVDS input data is 6bits, SELB set to High if LVDS input data is 8bits, SELB set to Low
26	GND	Ground
27	AVDD	Power for Analog Circuit
28	GND	Ground
29	VGH	Positive power for TFT
30	NC	Not connect
31	NC	Not connect
32	VGL	Negative power for TFT
33	GND	Ground
34	NC	Not connect
35	NC	Not connect



36	NC	Not connect
37	NC	Not connect
38	NC	Not connect
39	NC	Not connect
40	NC	Not connect

Note1 : UPDN and SHLR control function

SHLR	UPDN	Data shifting
DVDD	GND	Left→Right · Up→Down(default)
GND	GND	Right→Left · Up→Down
DVDD	DVDD	Left→Right · Down→Up
GND	DVDD	Right→Left · Down→Up

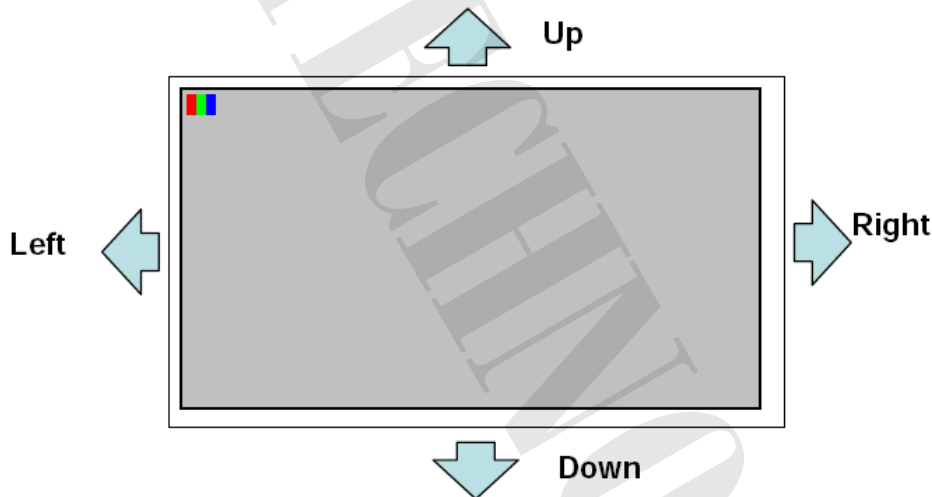

4.2 CN2 (backlight)

Pin No.	SYMBOL	FUNCTION
1	A	Anode
2	K	Cathode

Note :

Input connector : BHSR-02VS-1(JST)

Outlet connector: SM02B-BHSS-1(JST)



5. INPUT SIGNAL(DE ONLY MODE)

5.1 Timing Specification

Item	Symbol	Min.	Typ.	Max.	Unit		
LVDS input signal sequence	CLK Frequency	tclk	45	51.2	57	MHz	
LCD input signal sequence (Input LVDS Transmitter)	Horizontal	Horizontal total Time	t _H	1324	1344	1364	tCLK
		Horizontal effective Time	t _{HA}	1024			tCLK
		Horizontal Blank Time	t _{HB}	300	320	340	tCLK
	Vertical	Vertical total Time	t _V	625	635	645	t _H
		Vertical effective Time	t _{VA}	600			t _H
		Vertical Blank Time	t _{VB}	25	35	45	t _H

5.2 Timing sequence(Timing chart)

5.2.1 Horizontal Timing Sequence

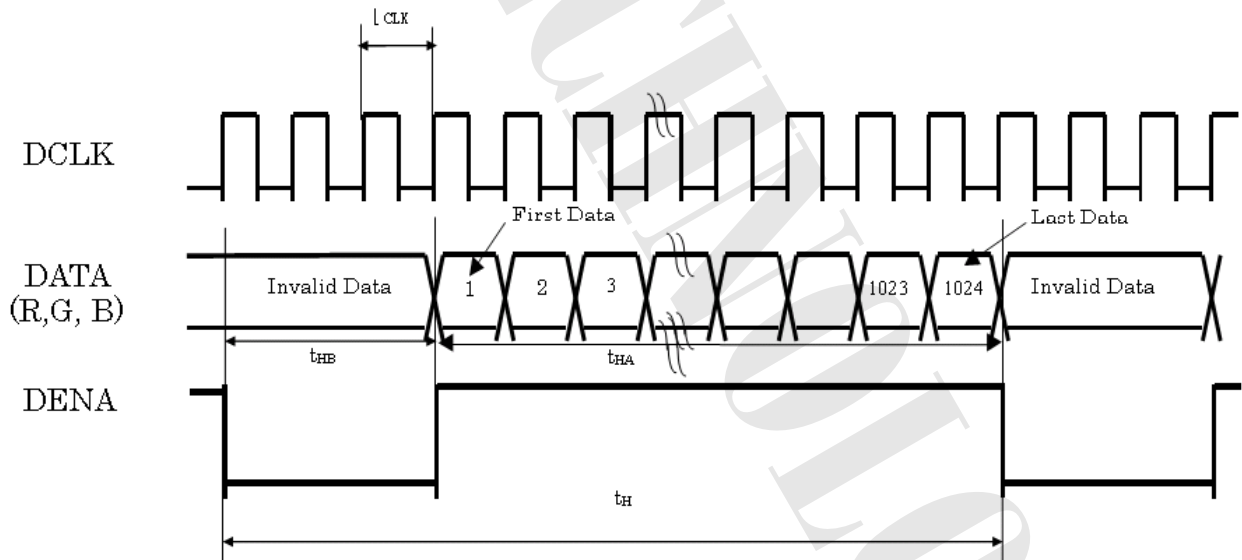

5.2.2 Vertical Timing Sequence

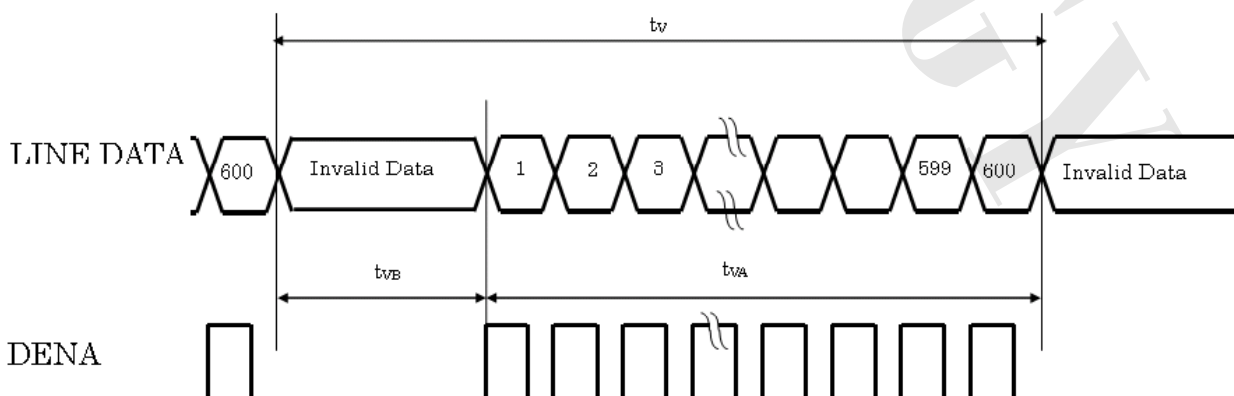



5.2.3 LVDS Input Data mapping

6 Bit LVDS input

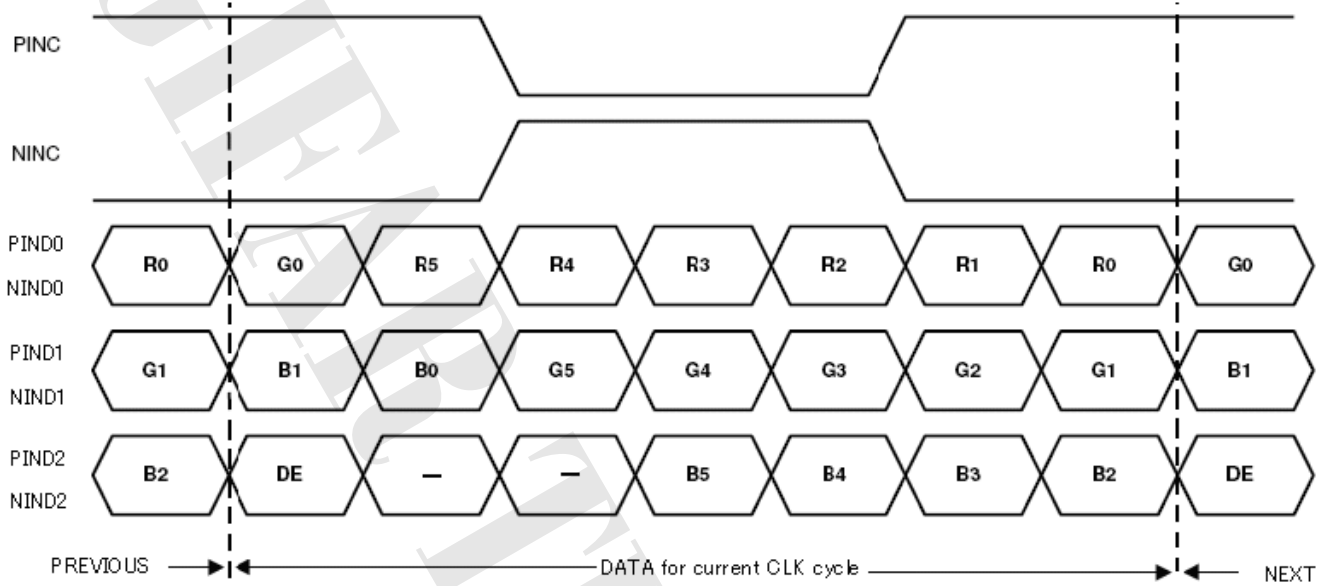

8 Bit LVDS input

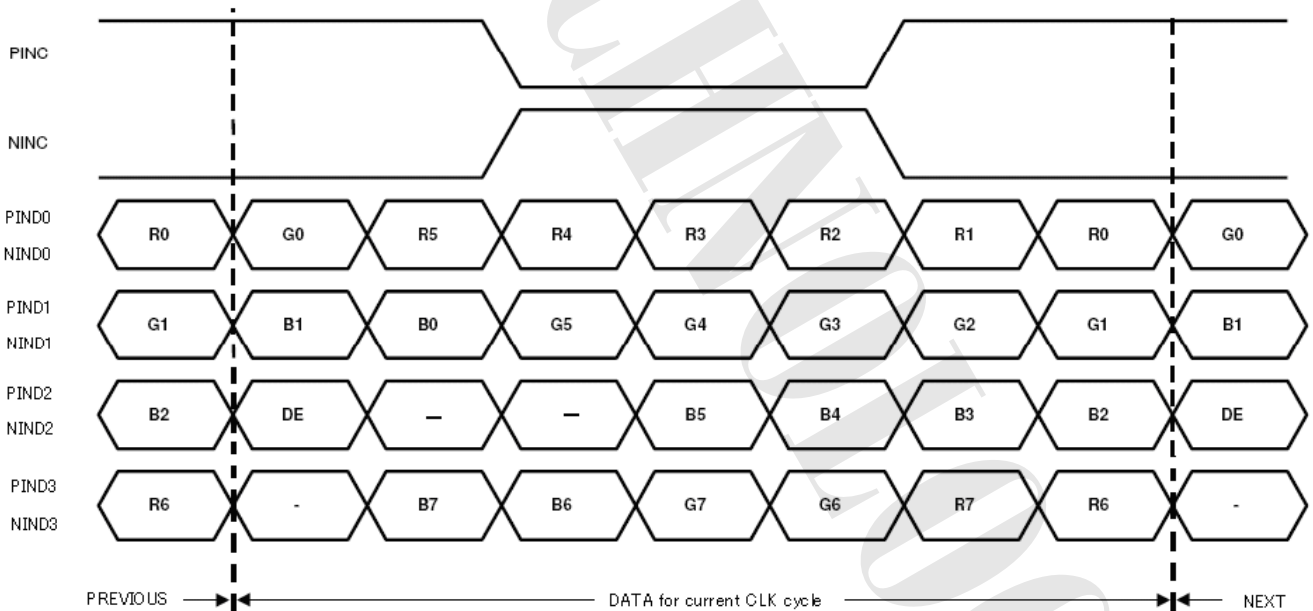



5.2.4 Color Data Reference

COLOR	INPUT DATA	R DATA								G DATA								B DATA							
		R7	R6	R5	R4	R3	R2	R1	R0	G7	G6	G5	G4	G3	G2	G1	G0	B7	B6	B5	B4	B3	B2	B1	B0
		MSB							LSB	MSB							LSB	MSB							LSB
BASIC COLOR	BLACK	0	0	0	0	0	0	0	0	0	0	0	0	0	0	0	0	0	0	0	0	0	0	0	0
	RED(255)	1	1	1	1	1	1	1	1	0	0	0	0	0	0	0	0	0	0	0	0	0	0	0	0
	GREEN(255)	0	0	0	0	0	0	0	0	1	1	1	1	1	1	1	1	0	0	0	0	0	0	0	0
	BLUE(255)	0	0	0	0	0	0	0	0	0	0	0	0	0	0	0	0	1	1	1	1	1	1	1	1
	CYAN	0	0	0	0	0	0	0	0	1	1	1	1	1	1	1	1	1	1	1	1	1	1	1	1
	MAGENTA	1	1	1	1	1	1	1	1	0	0	0	0	0	0	0	0	1	1	1	1	1	1	1	1
	YELLOW	1	1	1	1	1	1	1	1	1	1	1	1	1	1	1	1	0	0	0	0	0	0	0	0
	WHITE	1	1	1	1	1	1	1	1	1	1	1	1	1	1	1	1	1	1	1	1	1	1	1	1
RED	RED(0)	0	0	0	0	0	0	0	0	0	0	0	0	0	0	0	0	0	0	0	0	0	0	0	0
	RED(1)	0	0	0	0	0	0	0	1	0	0	0	0	0	0	0	0	0	0	0	0	0	0	0	0
	RED(2)	0	0	0	0	0	0	1	0	0	0	0	0	0	0	0	0	0	0	0	0	0	0	0	0
	RED(254)	1	1	1	1	1	1	1	0	0	0	0	0	0	0	0	0	0	0	0	0	0	0	0	0
	RED(255)	1	1	1	1	1	1	1	1	0	0	0	0	0	0	0	0	0	0	0	0	0	0	0	0
GREEN	GREEN(0)	0	0	0	0	0	0	0	0	0	0	0	0	0	0	0	0	0	0	0	0	0	0	0	0
	GREEN(1)	0	0	0	0	0	0	0	0	0	0	0	0	0	0	0	1	0	0	0	0	0	0	0	0
	GREEN(2)	0	0	0	0	0	0	0	0	0	0	0	0	0	0	1	0	0	0	0	0	0	0	0	0
	GREEN(254)	0	0	0	0	0	0	0	0	1	1	1	1	1	1	1	0	0	0	0	0	0	0	0	0
	GREEN(255)	0	0	0	0	0	0	0	0	1	1	1	1	1	1	1	1	0	0	0	0	0	0	0	0
BLUE	BLUE(0)	0	0	0	0	0	0	0	0	0	0	0	0	0	0	0	0	0	0	0	0	0	0	0	0
	BLUE(1)	0	0	0	0	0	0	0	0	0	0	0	0	0	0	0	0	0	0	0	0	0	0	0	1
	BLUE(2)	0	0	0	0	0	0	0	0	0	0	0	0	0	0	0	0	0	0	0	0	0	0	1	0
	BLUE(254)	0	0	0	0	0	0	0	0	0	0	0	0	0	0	0	0	1	1	1	1	1	1	1	0
	BLUE(255)	0	0	0	0	0	0	0	0	0	0	0	0	0	0	0	0	1	1	1	1	1	1	1	1

【Note】

1. Gray level : Color (n): n means level of gray scale. Larger n means brighter level.
2. Data : 1= High, 0 = Low



6. MECHANICAL DIMENSION

6.1 Front Side

(Unit : mm)

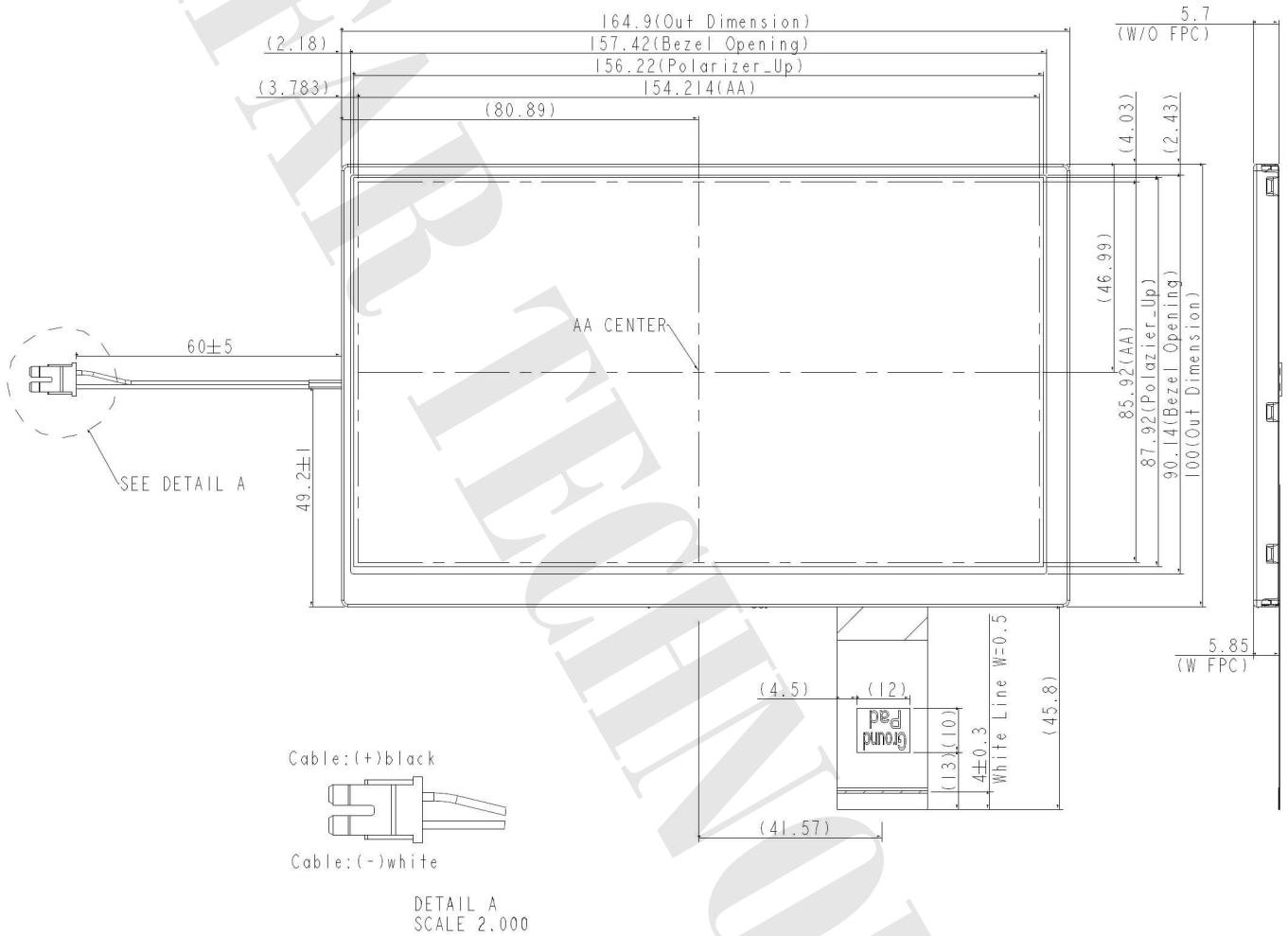

General tolerance=±0.3mm



6.2 Rear Side

(Unit : mm)

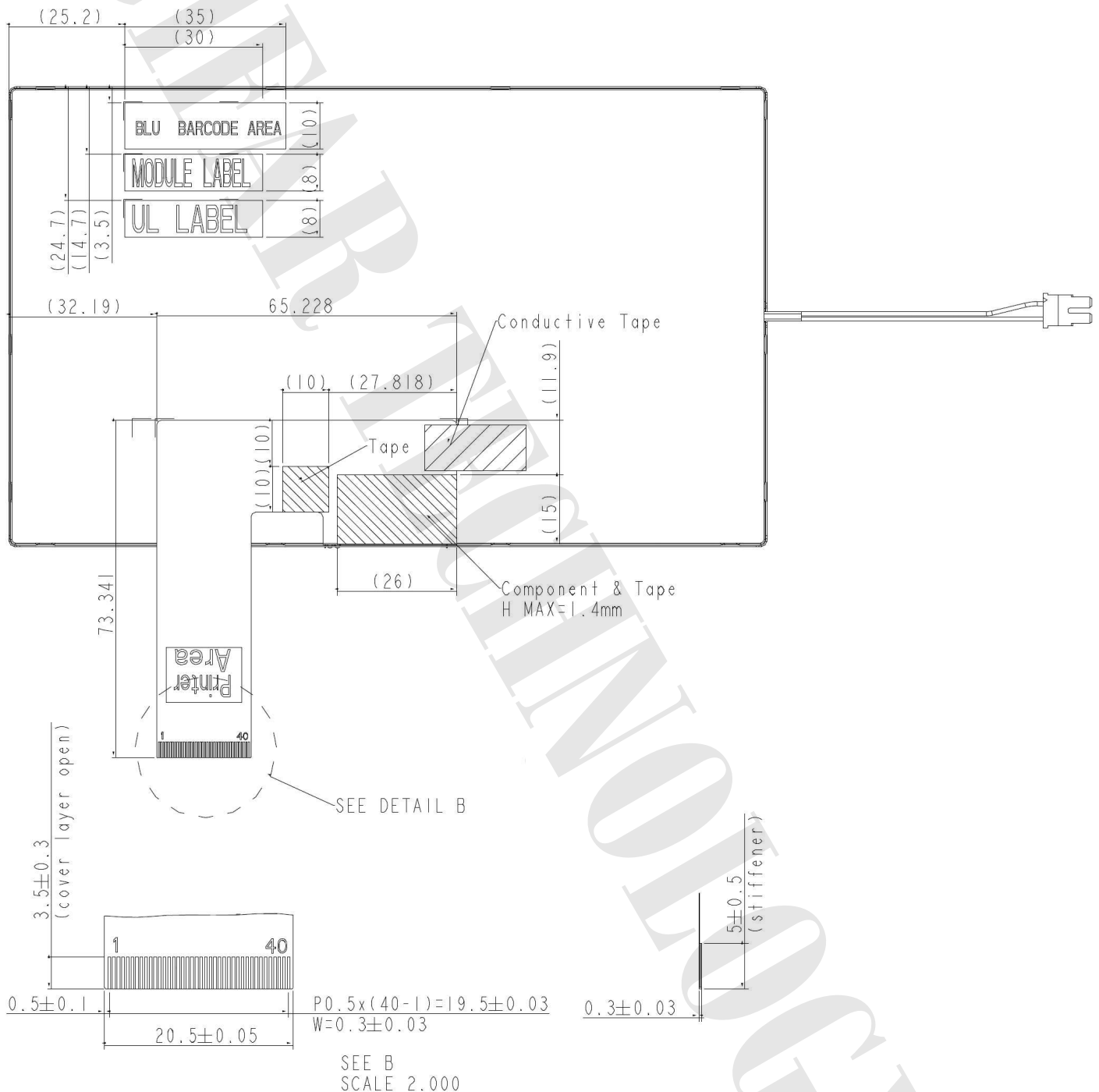

NOTE:

- 1.General tolerance=±0.3mm.
- 2.bending angel : minimum R=0.4 with 180 degrees
- 3.bending times : maxmun 3 times



7. OPTICAL CHARACTERISTICS

Ta=25°C VCC=3.3V

Item	Symbol	Condition	Min	Typ	Max	Unit	Remark	
Contrast Ratio	CR	Point-5	640	800	-	-	1, 2, 3	
Luminance(CEN)	Lw	Point-5	500	600	-	cd/m ²	1, 3	
Luminance Uniformity	ΔL		70	80	-	%	1, 3	
Response Time (White - Black)	Tr+Tf	Point-5	-	25	40	ms	1, 3, 5	
NTSC		-	40	50		%	1, 4	
Viewing Angle	Vertical	Upper(θ)	CR≥10 Point-5	50	60	-	°	1, 4
		Down(θ)		60	70	-	°	1, 4
	Horizontal	Left (Φ)		70	80	-	°	1, 4
		Right(Φ)		70	80	-	°	1, 4
Color Coordinate	White	Wx	Point-5	0.264	0.304	0.344	-	1, 3
		Wy		0.295	0.335	0.375		
	Red	Rx		0.549	0.589	0.629		
		Ry		0.301	0.341	0.381		
	Green	Gx		0.294	0.334	0.374		
		Gy		0.571	0.611	0.651		
	Blue	Bx		0.115	0.155	0.195		
		By		0.066	0.106	0.146		

Note1 : Measuring conditions : 25°C ±2°C , 60±10%RH , under 10Lux in the darkroom .

BM-5A (TOPCON) , view cone=2° IL=220mA (Backlight current) , measurement after 10 minutes operation.

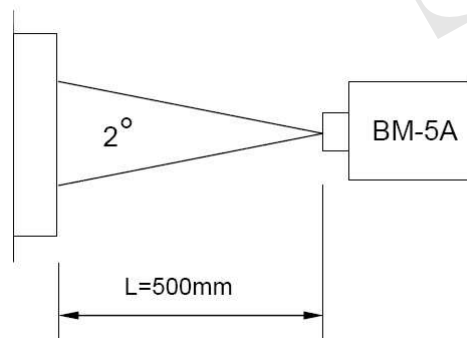

Note2: Definition of contrast ratio :

Contrast Ratio (CR)= (White) Luminance of ON ÷ (Black) Luminance of OFF

Definition of luminance : Measure white luminance on the point 5 as figure.7-1

$$\Delta L = [L(\text{MIN})/L(\text{MAX})] \times 100$$



Note3: Definition of luminance : Measure white luminance on the point 5 as figure.7-1

Definition of Luminance Uniformity: Measure white luminance on the point1~9 as figure.7-1

$$\Delta L = [L(\text{MIN})/L(\text{MAX})] \times 100$$

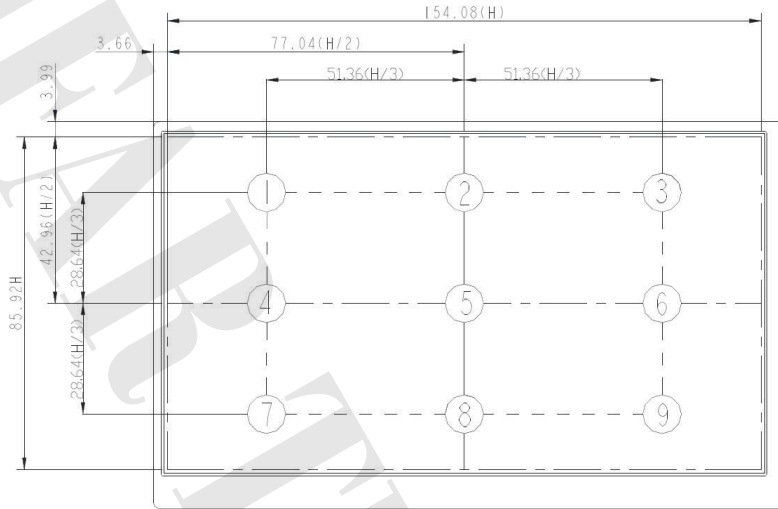

Fig.7-1 Measuring point

Note 4: Definition of Viewing Angle (θ , Φ), refer to Fig.7-2 as below

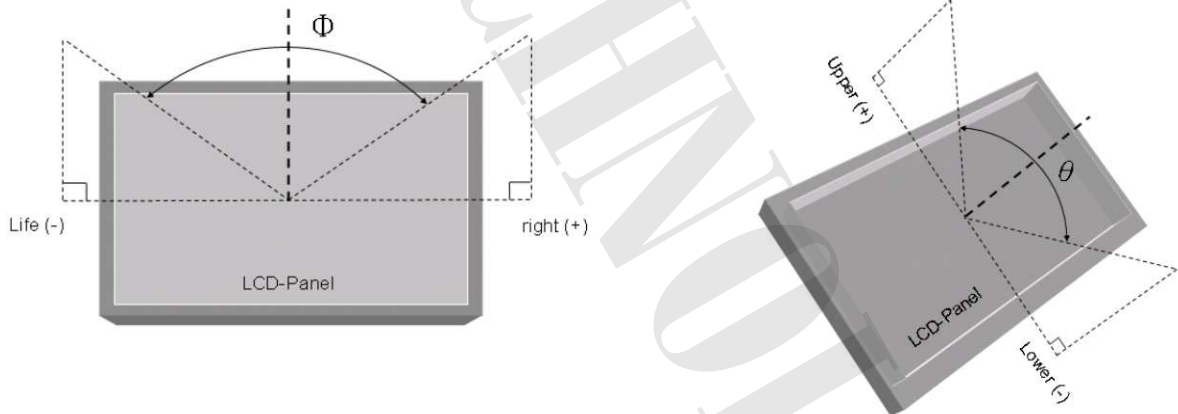

Fig.7-2 Definition of Viewing Angle

Note 5: Definition of Response Time. (White - Black)

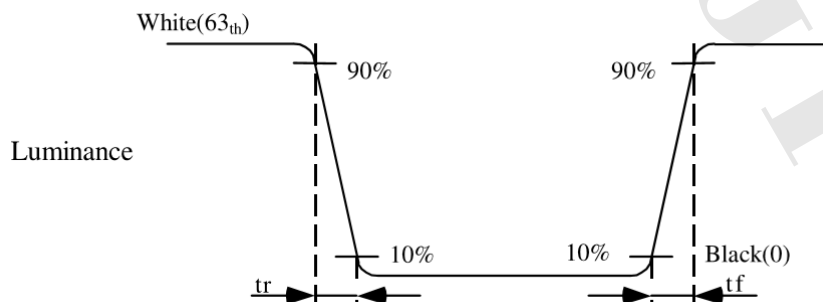

Fig.7-3 Definition of Response Time(White-Black)



8. RELIABILITY TEST

8.1 Temperature and Humidity

TEST ITEMS	CONDITIONS	NOTE
High Temperature Operation	70°C, 240hrs	
High Temperature Operation	80°C _{TP} , 240hrs	Note 1
High Temperature Storage	80°C, 240hrs	
High Temperature High Humidity Operation	60°C, 90%RH, 240hrs	
Low Temperature Operation	-20°C, 240hrs	
Low Temperature Storage	-30°C, 240hrs	
Thermal Shock	-20°C(0.5hr)~ 70°C(0.5hr); 100 Cycle	Non-Operating
Image Sticking	25°C, 4hrs	Note 2

Note 1 : . T_p: panel surface temperature overall.

Note 2. Condition of Image Sticking test : 25°C±2°C

Operation with test pattern sustained for 4 hrs, then change to Mid-gray pattern immediately.
After 5 mins, the mura must be disappeared completely .

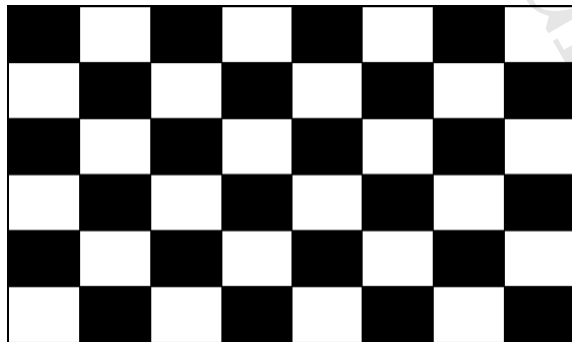

Image Sticking -pattern



Mid-Gray pattern

8.2 Shock and Vibration

TEST ITEMS	CONDITIONS
Shock (Non Operation)	<ul style="list-style-type: none"> ● Shock level: 980m/s² (equal to 100G). ● Waveform: 1/2 Sine wave,6msec ● Number of shocks: ±X , ±Y , ±Z , each axis 1 times
Vibration (Non Operation)	<ul style="list-style-type: none"> ● Frequency range : 8~33.3Hz ● Stroke : 1.3 mm ● Vibration: sinusoidal wave, perpendicular axis (both x, z axis: 2hrs ,y axis: 4hrs). ● weep: 2.9G,33.3 Hz -400 Hz ● Cycle:15 min



8.3 Electrostatic Discharge

Item	Conditions	Remarks
ESD (power off)	150 pF、330Ω、±8KV,±15KV air & contact test	1
	200 pF、0Ω、±200V contact test	2

Note : Measure

- 1: LCD glass and metal bezel
- 2: IF connector pins

8.4. Judgment standard

The judgment of the above test should be made as follow :

Pass : Normal display image with no line defect.

Partial transformation of the module parts should be ignored.

Fail : No display image, Function NG, or line defects.



9. PACKING

9.1 Packing order:

- (1) Box Dimension: 470mm(L) X 360mm(W) X 189mm(H)
- (2) Package Quantity in one Box : 50pcs
- (3) Weight: approximately 9.3Kg

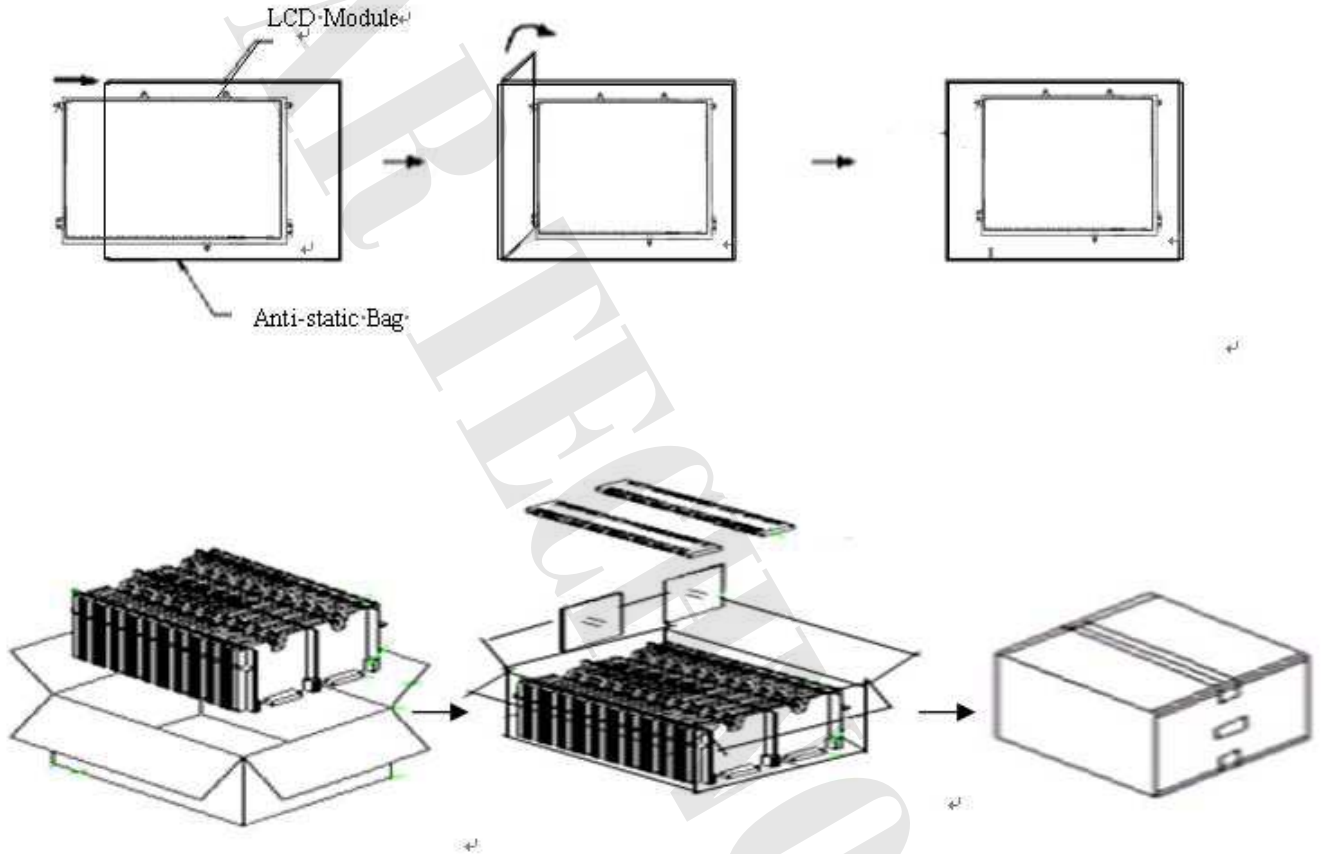

10. WARRANTY

10.1. The period is within 12 months since the date of shipping out under normal using and storage conditions.

10.2. The warranty will be avoided in case of defect induced by customer.